

## Flame-, plasma- and laser products

THE OPTIMUM SYSTEM  
FOR EVERY APPLICATION

We have been using and developing the latest CNC technologies for more than 10 years now, offering the highest quality and production rate to our customers.

Be it complete equipment, individual units, processing technology or lease-work, we are sure that the speed, productivity, customizing options and our competitive prices will be appealing to you.

Certain items of our developed prototypes are commercially available, while others are integrated into our lease-work service. This way our production, distribution and end-user experiences guarantee an excellent cooperation with our customers.



Flame cutting



Laser cutting



Milling



Plasma cutting



Waterjet cutting



### **From complete equipments to components**

We offer customized solutions for the complete installation of any technology suited for your individual production demands. In addition to that we offer individual units to several technologies, representing many international companies.

### **Spare part production**

Our company produces different spare parts form materials ranging from plastics to aluminium alloys and tempered steel. By using several technologies, we have the option to cut and process every material.

### **Service**

We offer contract-based preventive maintenance mainly for our own equipment but also for systems built by other companies, as well. Our team and fleet of ten service cars are at your disposal any time you need engineering help.

# Content

## MECHANICS

PreciTrack coordinate system.....	2
-----------------------------------	---

## FLAME CUTTING

General description.....	4
PreciTrack PTF2030 .....	5
Machine Cutting Torches FIT+ and BIR+ .....	6

## PLASMA CUTTING

General description.....	9
PreciTrack PTP2030 .....	11
PreciTrack PTPF2030.....	12
HiFocus 80i .....	13
HiFocus 130 neo .....	15
HiFocus 161i neo.....	17
HiFocus 280i, 360i, 440i neo.....	19
HiFocus 600i neo.....	21
FineFocus 450, 600, 800, 1600 .....	22
SmartFocus 130, 200, 300.....	25
New: SmartFocus 400.....	27
PA-S45W, PA-S70W.....	28
CutFire 65i, 100i.....	30
CUTi, CUTLINE.....	32
FineMarker.....	34
Plasma Cutting with Robots.....	35
HotWire Plasma.....	37
Plasma Gas Unit - FlowControl.....	38
Automatic Torch Changer.....	39

## LASER TECHNOLOGY

General description.....	40
PreciTrack PTL2030 .....	41
Fiber Laser XFocus 500, 1000, 2000.....	42
SPI Fiber Laser Sources .....	44
Cutting optics.....	46

## HEIGHT CONTROL UNITS

KHC4-PCS .....	49
B 1000 .....	51

coordinate track equipped with NCT control system

## **Preci**rack® coordinate system



### **Features**

- Path system suitable to be enlarged in modular way
- Structure made of a special alloy
- 3-component nano-composite lining
- Surprisingly light, yet, extraordinary rigid design
- Joint planes machined with high accuracy
- Axes and machine stay-plates measured by laser interferometer
- A,B,Z axes for 3 to 5-axis machining
- Speed of axes of 130 m/min with 1 G acceleration
- 0,01 mm accuracy of positioning and repetition
- Space measuring system with 3 micrometer scale division
- GANTRY axis synchronism
- Surface treated precision drive mechanism, with inclined cogging
- Compact Compact technology-carrier bracket with threefold linear guiding and zero pitching
- Protection of saddle against pollution by means of rubber mantle made of fire- and water resistant elements
- Sectioned cabin within the work area, operator console of ergonomic design with spacious margin
- Space saving design, easy transportability, installation possibility on extreme sites.

### **Modular design**

A system suitable to be built of elements that offers a number of possibilities in respect of both the work space and equipment. The useful work area can be increased in a cost-effective way at any time up to as high as 6000 x 30 000 mm size. The processing technology can be changed even posteriorly and the machine can be enlarged with other optional features. Operator cabin within the work area and work benches of various design are also available on request.

### **Light and compact design**

It is made of structural elements composed of special alloy by using individual welding technology. It has a rigid and vibration-free crosswise bridge structure of optimized centre of gravity. An integrated lengthwise train is built on its legs fit into another strutted in several directions.

## Preciseness

The base plates of the structure are levelled by means of a laser interferometer. All of its components are levelled by milling on the whole surface of junction points. It is driven along the XY axis by means of a surface-treated precision gear-rack of inclined cogging made of strengthened alloy suitable to be ranked. The drive along the Z axis is backlash-free, provided with a high precision ball spindle. In case of AB rotating axles, a high precision backlash-free wave-drive will be built-in. The parallelism of Gantry axles is measured by means of microscope-aided threads. Linear leads along each axis and threefold guide in crosswise direction are mounted. The drives are of ground gears and the mechanical structure is assembled with high precision.

## Advanced control- and drive system NCT and Beckhoff controls

- Intelligent control software with intuitive graphic interface
- Professional operator console with touch screen
- Handling of as much as 64K axis and 8 virtual machine simultaneously
- Graphic PLC with optional machine functions
- Heidenhain-type absolute space measuring system (3µm)
- Nano interpolation, vector feed-forward
- HSHP path follow-up, closed-loop position control
- Acceleration according to third degree function (bell shape)
- Digital AC servo drives on EtherCAT bus

HSHP = High speed & High Precision

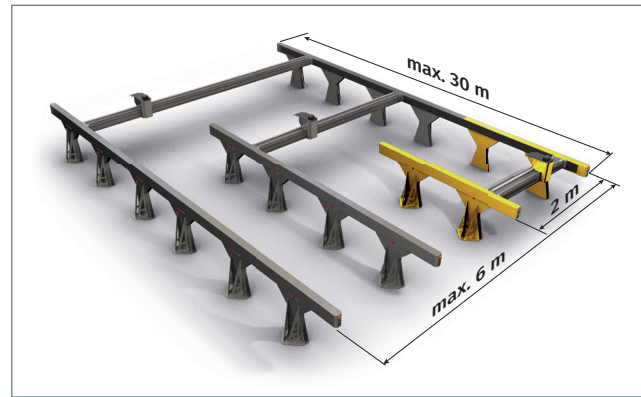

## Dynamics

The balanced drives integrated into the bridge ensure the highest possible speed and acceleration. Digital AC servomotors of optimum inertia with unparalleled acceleration operate on each axis. The moving bracket is of compact design; fast and pitch-compensated.

## Efficiency

The continuous preciseness of mass-production with minimum energy consumption, the shortest possible production lost-times and little maintenance requirements is guaranteed. It is recommended in all the fields of application where flexible, cost-effective CNC equipment with low space requirement and low purchase cost is required.

## Protection, reliability

It is provided against pollution of vapor, smoke, chips, dust and other wastes by a full longitudinal cover, a cross-wise fire resistant bellow as well as a closed Z console that minimize the maintenance requirements of the mechanics. It is equipped with a central grease lubrication system with dosing as required. It is mounted with operator cabin within the work area in order to filter out the noise and production by-products. It is provided with multiple safety loop for the protection of the operator and the environment.

# about the Flame cutting technology

## About flame cutting

Flame cutting is oxygen cutting in which the appropriate part of the material to be cut is raised to ignition temperature by an oxy-fuel gas flame. Also known as oxy-fuel cutting, the process is used for separating and shaping steel components. It is carried out using a torch through which oxygen and a fuel gas (acetylene, propane or mains gas) are passed. An outer ring of jets in the torch nozzle are used to preheat the surface of the steel. A separate oxygen stream is directed from a central jet on to the area to be cut. Rapid oxidation of the steel takes place and material is removed by the pressure of the gases. The process may be manual, where the cutting torch is held and guided by the operator, or mechanised, where the torch may be mounted on a machine. Cutting of complex shapes is possible. Cutting machines may be pre-programmed, using computer technology, to minimise material wastage of plate being cut. Multi-cutting head machines are available for high volume production applications. Flame cutting is most suitable for steels with low carbon content.

## The conditions of flame cutting

- The metal can be burned in oxygen.
- The ignition point of the metal is below its melting point.
- The melting point of the oxide of the metal is lower than the melting point of the metal.
- Low heat-conductive characteristics but high ignition heat.
- The product of the ignition must be liquid.

## The advantages of flame cutting

- The largest possible cutting thickness (up to 300 mm).
- The cutting source itself is the least expensive among all cutting technologies.
- Minimal maintenance demands compared to other systems.
- Easy operation.
- Relatively good tolerance limits in case of experienced operators (even  $\pm 0.5$  mm).

## Cutable materials

In industrial practice it is mainly used for the cutting of non-alloy structure steel items. Ideal for cutting thick plates and very cost-effective.

## Gases used for flame cutting

Thicker materials require higher oxygen pressure and nozzle size. The purity of oxygen should be at least 99.5%. A decrease in purity of 1% will typically reduce the cutting speed by 25% and increase the gas consumption by 25%. Naturally it is more expensive to produce oxygen of higher purity but its cost will return in the long run. Flame cutting is an advantageous method for cutting steels with low carbon content. Preheating the material is more cost-effective. In case of cutting steel at 700-900 °C the cutting speed can be triple.

complete flame cutting equipment

# PreciTrack® PTF2030

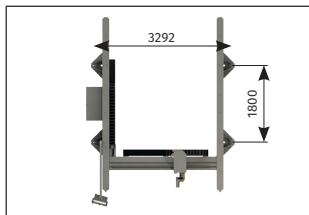
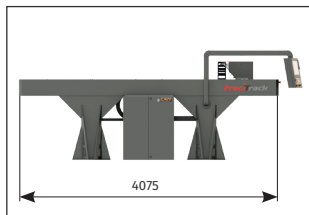
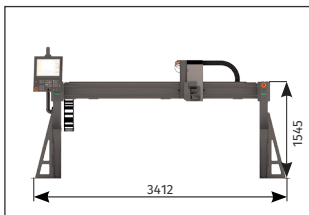

PreciTrack PTF2030 Technical data	
X Y Z Axis	3418x3850x1700 mm
Work area	3000x2000 mm
Weight	~ 1500 kg
Load capacity	~ 3000 kg
Power	~ 6 kW
Drive	Digital AC servo
Rapid traverse speed X	60 m/perc
Rapid traverse speed Y	60 m/perc
Rapid traverse speed Z	30 m/perc
Maximal step precision	0,01 mm
Operational step precision	0,05 mm
Retrack precision	0,05 mm
Cutting technology	GCE
No. of heads	1 db
Type of cutting head	220/32 PMY+ PB
Max. noise level dB(A)	80 dB
Control	NCT201

We designed the complete unit above according to the industrial averages so it is an applicable solution for most manufacturers but if you have other production demands you can naturally order a different configuration, as well. Due to the PreciTrack coordinate track the size, technology and accessory units can be changed in a flexible way.

for the thickest materials

# Machine Cutting Torches FIT+ and BIR+



## INJECTOR TORCH RANGE GCE FIT+®

GCE FIT+® is unique system for oxy-fuel machine cutting technology. The long-term partnership with the customers resulted in the product concept creation. This product line is based on the wide experience with cutting application, one of the traditional fields of GCE activities. The main philosophy of GCE FIT+® is to make cutting process safe, efficient and operator friendly.

Torch is suitable for use with cutting nozzle types (High speed ASF, rapid cutting ARC) for acetylene and (High speed PSF, rapid cutting PRC) for propane, natural gas and mixed fuel gases.

- High productivity of oxygen machine cutting process due to high-speed cutting nozzles
- Safe operations ensured by integrated COOLEX® and axial injector with application of RMS (Resonator Mixing System) in acetylene variants
- Working efficiency with minimized nozzles exchange time
- Easy handling for machine operators because of Tool-Free nozzles changing system
- Nozzles fixation done manually by special bayonet system, without any wrench
- One type of heating nozzle for all fuel gases
- Extended lifetime of heating nozzle
- Provided in accordance with ISO 5172

## APPLICATION FIELDS

- Oxygen cutting of straight and shape cuts in accordance with ISO 9013
- Oxygen cutting 3 - 300 mm
- Hole piercing up to 150 mm
- Applications with different fuel gases
- Prepared for all cutting machines

Art. Nr.	Length / diameter	Fuel gas	Connections
0766121	220 / 32	Acetylen	G3/8", G3/8"LH, G1/4"
0766164	320 / 32	Acetylen	G3/8", G3/8"LH, G1/4"
0766223	110 / 32	Acetylen	G3/8", G3/8"LH, G1/4"
0766122	220 / 32	PMY	G3/8", G3/8"LH, G1/4"
0766165	320 / 32	PMY	G3/8", G3/8"LH, G1/4"
0766224	110 / 32	PMY	G3/8", G3/8"LH, G1/4"



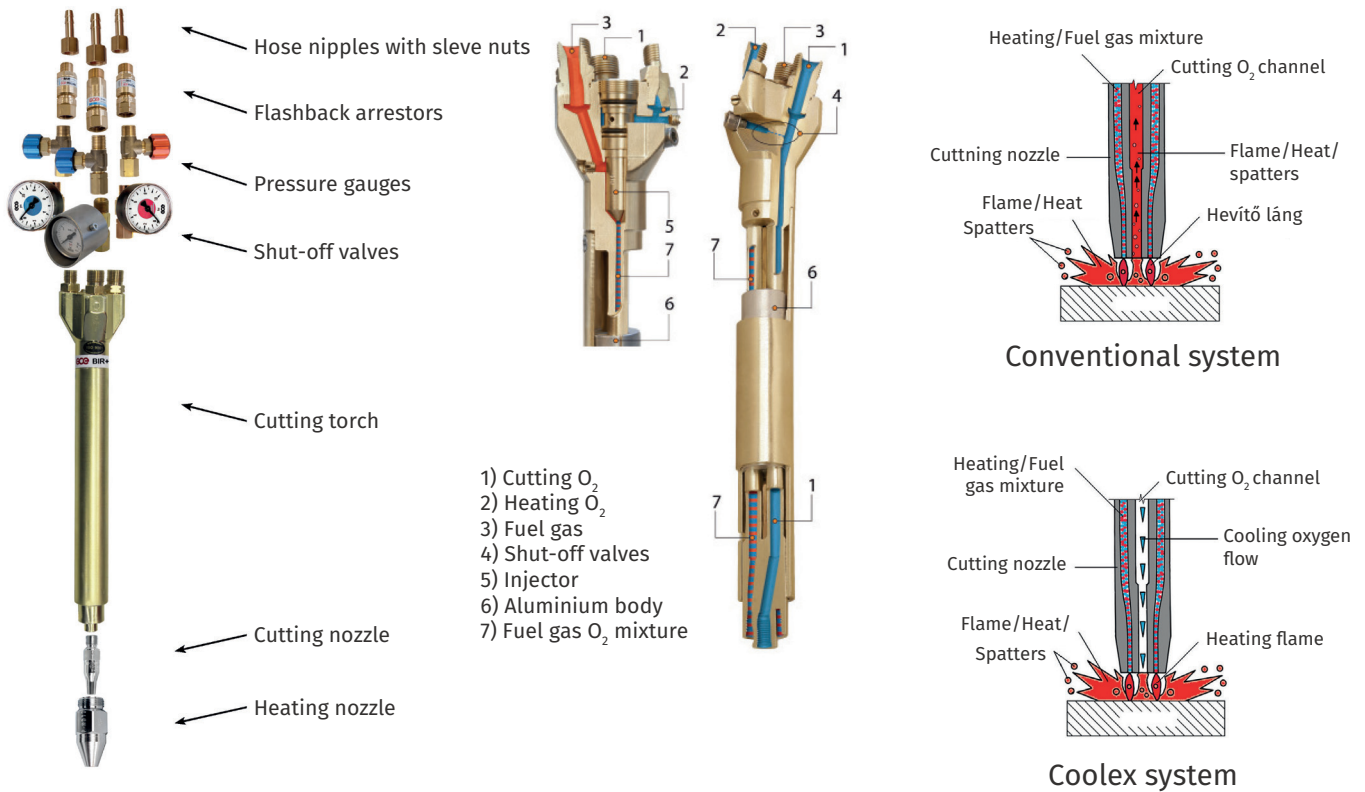

## Integrated Coolex system

- The BIR+ contains a cool flow valve which provides a small amount of oxygen during preheating of the basic material. This small oxygen flow is streaming through the cutting oxygen channel to cool down the complete torch system and prevents the reverse flow of hot gases in to the cutting nozzle. The nozzle will be protected against early contamination.
- Longer nozzle life time
- Lower system temperature
- Constant shape of gas channels
- Constant gas flows

## Safety Injector

- A safety injector covered in a stable brass body is the basis for a safe function. Any overheating will be transported away from the injector which protects the torch against sustained backfire.
- Downstream of the injector an aluminium cooling unit completes the cooling function of the BIR torch which guarantees high operation safety. Sustained backfire hazard is minimized, also during extremely high load.
- High operation safety while hole piercing
  - High service life of torch + nozzle
  - High economy
  - Less maintenance

Type	Gas	Cooling valve	Shaft (length/Ø mm)
BIR 220/32 PMY	PB/Natural gas	no	220/32
BIR 220/32 PMY +	PB/Natural gas	yes	220/32
BIR 220/34 PMY	PB/Natural gas	no	220/34
BIR 220/34 PMY +	PB/Natural gas	yes	220/34
BIR 220/32 A	Acetylene	no	220/32
BIR 220/32 A +	Acetylene	yes	220/32
BIR 220/34 A	Acetylene	no	220/34
BIR 220/34 A +	Acetylene	yes	220/34



PUZ 89 cutting nozzle

Cutting range (mm)	Cutting speed (mm/perc)	Cutting O <sub>2</sub> press. (bar)	Heating O <sub>2</sub> press. (bar)	Fuel gas press. (bar)	Cutting O <sub>2</sub> cons. (m <sup>3</sup> /h)	Heating O <sub>2</sub> cons. (m <sup>3</sup> /h)	Fuel gas cons. (m <sup>3</sup> /h)
25-40	340-400	4,0-5,0	2,5	0,2	2,8-3,4	1,5	0,3
40-60	310-340	4,5-5,5	2,5	0,2	4,6-5,6	1,5	0,38
60-100	260-310	5,0-6,0	2,5	0,2	8,1-9,5	1,5	0,38
100-200	180-260	5,5-6,5	3,0-5,0	0,3	12,6-14,4	1,7-2,5	0,5-0,7
200-300	110-180	6,5-8,5	5,0-7,0	0,3	12,6-14,4	2,5-3,3	0,7-0,9

P-SD cutting nozzle

Cutting range (mm)	Cutting speed (mm/perc)	Cutting O <sub>2</sub> press. (bar)	Heating O <sub>2</sub> press. (bar)	Fuel gas press. (bar)	Cutting O <sub>2</sub> cons. (m <sup>3</sup> /h)	Heating O <sub>2</sub> cons. (m <sup>3</sup> /h)	Fuel gas cons. (m <sup>3</sup> /h)
25-40	400-460	6,0-7,5	2	0,2	3,8-4,5	1,3	0,32
40-60	340-400	5,5-7,5	2	0,2	4,2-5,6	1,3	0,32
60-100	270-340	6,0-8,5	2	0,2	7,6-10,6	1,3	0,32
100-150	180-270	7,5-9,5	4,5	0,3	13,3-16,5	2,4	0,32
150-250	130-180	6,5-8,5	4,5	0,3	18-22	2,4	0,6
250-300	110-130	6,5-8,5	5	0,3	23-30	2,4	0,62

PY-HD10 cutting nozzle

Cutting range (mm)	Cutting speed (mm/perc)	Cutting O <sub>2</sub> press. (bar)	Heating O <sub>2</sub> press. (bar)	Fuel gas press. (bar)	Cutting O <sub>2</sub> cons. (m <sup>3</sup> /h)	Heating O <sub>2</sub> cons. (m <sup>3</sup> /h)	Fuel gas cons. (m <sup>3</sup> /h)
24-40	390-500	8,5-11	2,5	0,2	3,6-4,6	1,3	0,38
40-60	320-390	9-12	2,5	0,2	6,7-8,6	1,3	0,38
60-100	280-320	9,5-11	2,5	0,2	8,9-10,1	1,3	0,38
100-150	180-270	7,5-9,5	4,5	0,3	13,3-16,5	2,4	0,6
150-250	130-180	6,5-8,5	4,5	0,3	18-22	2,4	0,6
250-300	110-130	6,5-8,5	5	0,3	23-30	2,4	0,62

# the optimum cutting system for each application

## Plasma cutting

**Kjellberg is the longest established manufacturer of plasma cutting technique in the market and offers plasma and laser cutting technique for a wide range of different cutting tasks. With the high-quality products made in Germany excellent results can be achieved for automated, mechanised or manual cutting. Users acquire powerful state-of-the-art systems and advanced cutting technologies which can be used in diverse application areas.**

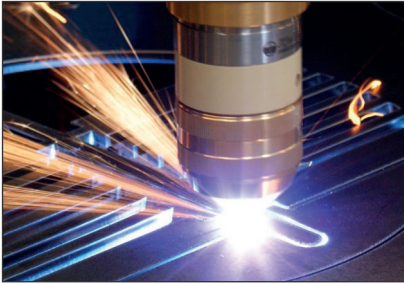

2D plasma



3D plasma

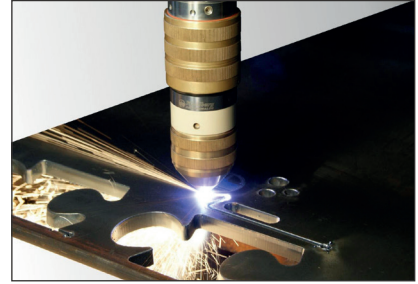

Contour Cut



Underwater plasma

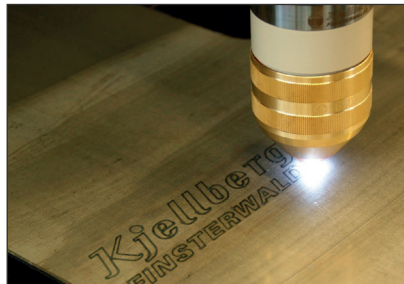

Marking

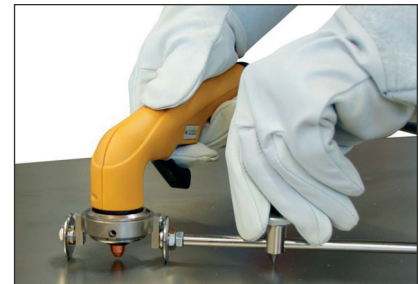

Manual plasma

In the industry today, HiFocus plasma cutting is a synonym for highest cutting quality and best perpendicularity. Furthermore, the strong constriction of the arc allows very fine cutting of thin plates with a very small current.

### **Dry plasma cutting**

Dry plasma cutting is often referred to as conventional or standard plasma cutting. However, the historic development should be regarded in a more differentiated way. Conventional plasma cutting means that the arc is only focussed by the inner diameter of the nozzle

### **Underwater plasma**

The development of underwater plasma cutting originated in the special requirements of industrial cutting applications. Among other things, the noise pollution, radiation and

dust exposure as well as material distortions caused by heat input should be reduced.

### **HiFocus neo – efficient plasma cutting**

When using the HiFocus technology for plasma cutting, a swirl gas is added which rotates around the plasma beam at very high speed and constricts the plasma beam heavily. The rotation of the swirl gas has the effect that the plasma beam is stabilised and protected. A big advantage for users is that this technology allows nearly rectangular cut surfaces within a broad range of material thicknesses.

## Marking, Notching and Punching with Plasma

The high-precision plasma cutting systems of the HiFocus series with inverter technology - marked with an „i“ in their names - already have this marking function (exception: HiFocus 80i). It allows cutting and marking without changing the consumables of the torch.

These inverter power sources achieve the best marking quality in the plasma industry in particular due to the extremely low marking currents from 5 A and the use of argon as marking gas.

## Contour Cut Technology

Contour Cut stands for the precise cutting of mild steel. When cutting small contours, narrow bars and especially small holes with a diameter to thickness ratio of 1:1 an outstanding cut quality is achieved. Smooth cut surfaces and sharp cut edges reduce time-consuming aftertreatment. Thus, productivity increases while costs are reduced.

Contour Cut and Contour Cut Speed are standard in all HiFocus neo units with the plasma torches PerCut 200-211 and PerCut 440-451. Upgrades of your existing HiFocus systems are available on request.

## Parameters for the family of HiFocus

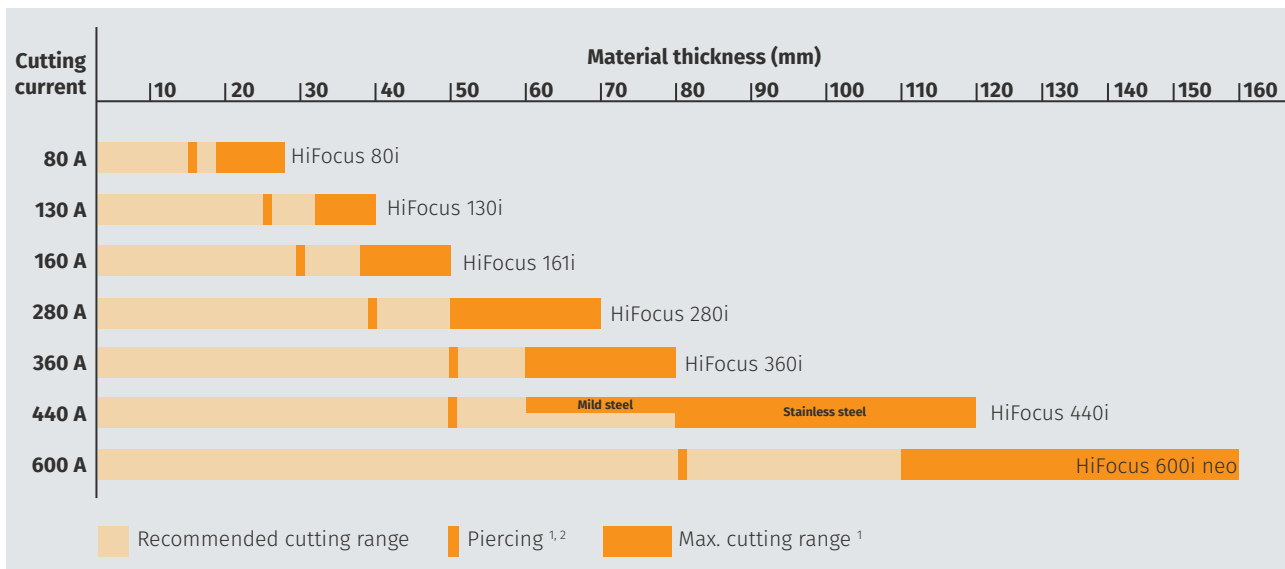

<sup>1</sup> These data are depending on the materials to be cut and their compositions. <sup>2</sup> Observe piercing capability!

Power source	HiFocus 80i	HiFocus 130	HiFocus 161i	HiFocus 280i	HiFocus 360i	HiFocus 440i	HiFocus 600i neo
Mains voltage <sup>3</sup>	3~, 400 V, 50 Hz						
Fuse, slow	25 A	50 A	50 A	100 A	125 A	200 A	
Connected load	17 kVA	32 kVA	28 kVA	67 kVA	87 kVA	127 kVA	93 kVA
Cutting current (100% d.c)	10 - 80 A	20 - 130 A	10 - 160 A	10 - 280 A	10 - 360 A	10 - 440 A	100-300 A
Marking current	-	16 A	5 - 25 A	5 - 50 A	5 - 50 A	5 - 50 A	-
Dimensions (H x W x D)	970 x 510 x 970 mm	960 x 540 x 1050 mm	985 x 570 x 1140 mm	1030 x 680 x 1450 mm			
Weight	161 kg	251 kg	206 kg	505 kg	517 kg	589 kg	
Plasma gas	O <sub>2</sub> , N <sub>2</sub>	O <sub>2</sub> , Ar, H <sub>2</sub> , N <sub>2</sub>	O <sub>2</sub> , Ar, H <sub>2</sub> , N <sub>2</sub>	O <sub>2</sub> , Ar, H <sub>2</sub> , F5*	O <sub>2</sub> , Ar, H <sub>2</sub> , F5*	O <sub>2</sub> , Ar, H <sub>2</sub> , F5*	
Marking gas	-	Ar	Ar	Ar	Ar	Ar	
Swirl gas	O <sub>2</sub> , N <sub>2</sub> , Air, F5*	O <sub>2</sub> , N <sub>2</sub> , Air, F5*	O <sub>2</sub> , N <sub>2</sub> , Air, F5*	O <sub>2</sub> , N <sub>2</sub> , Air	O <sub>2</sub> , N <sub>2</sub> , Air	O <sub>2</sub> , N <sub>2</sub> , Air	

<sup>3</sup> Other voltage and frequencies on request. \* Forming gas F5 (95 % N / 5 % H)

complete plasma cutting equipment

# PreciTrack® PTP2030

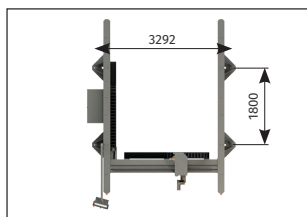
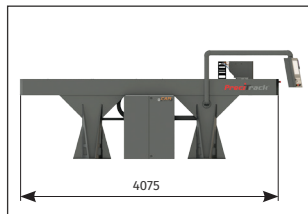
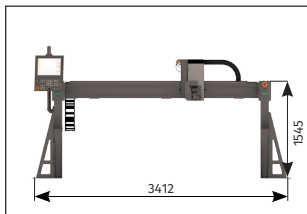

PreciTrack PTP2030 Technical data	
X Y Z Axis	3418x3850x1700 mm
Work area	2000x3000 mm
Weight	~ 1500 kg
Load capacity	~ 3000 kg
Power	17-50 kW
Drive	Digital AC servo
Rapid traverse speed X	60 m/min
Rapid traverse speed Y	60 m/min
Rapid traverse speed Z	30 m/min
Maximal step precision	0,01 mm
Operational step precision	0,05 mm
Retrack precision	0,05 mm
Cutting technology	HiFocus Plazma
No. of heads	1
Max. cutting current	160 A
Max. noise level dB(A)	80 dB
Control	NCT201

We designed the complete unit above according to the industrial averages so it is an applicable solution for most manufacturers but if you have other production demands you can naturally order a different configuration, as well. Due to the PreciTrack coordinate track the size, technology and accessory units can be changed in a flexible way.

complete plasma-flame cutting equipment

# PreciTrack® PTPF2030

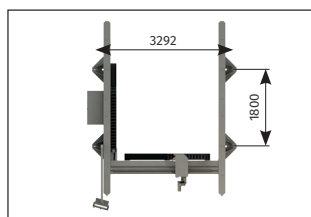
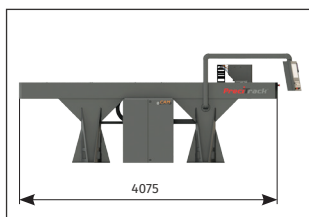
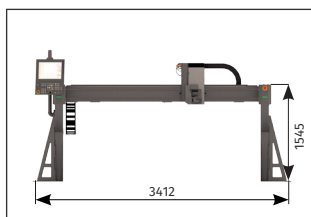

### PreciTrack PTPF2030 Technical data

X Y Z Axis	3418x3850x1700 mm
Work area	1500x3000 mm
Weight	~ 1600 kg
Load capacity	~ 3000 kg
Power	~ 36 kW
Drive	Digital AC servo
Rapid traverse speed X	60 m/perc
Rapid traverse speed Y	60 m/perc
Rapid traverse speed Z	30 m/perc
Maximal step precision	0,01 mm
Operational step precision	0,05 mm
Retrack precision	0,05 mm
Cutting technology	HiFocus Plazma, BIR inj.
No. of heads	2 db (plazma+lâng)
Max. cutting current	160 A
Max. noise level dB(A)	80 dB
Control	NCT201

We designed the complete unit above according to the industrial averages so it is an applicable solution for most manufacturers but if you have other production demands you can naturally order a different configuration, as well. Due to the PreciTrack coordinate track the size, technology and accessory units can be changed in a flexible way.

# small but highly precise plasma cutting system

## HiFocus 80i



### The HiFocusPlus technology has a number of advantages

- Minimum gas and energy consumption due to high energy density as a result of the increased constriction of the plasma arc
- Excellent cutting quality
- Low perpendicularity and inclination tolerances of the cuts
- High contour accuracy of sharp edges and small radii
- Low heat input and, therefore, low material warping
- Flexible adjustment of the cutting process to the required conditions
- Optimal process control due to quick and stepless adjustment of the cutting current
- Individual manual adjustment of gases with the plasma gas control unit PGE3-HM
- Analogue or serial interface for adaption of robots to CNC control
- Serial data transfer to PC for diagnostic purposes
- Optimal piercing due to adjustable current upslope
- Adjustable current downslope after corner, start and end signals from the guiding system

### HiFocus 80i System of Function and Design

The HiFocus 80i is a modern microprocessor-controlled power source that is often used in the automotive industry. Based on the well-proven soft switch inverter technology with primary switching and with an operating range from 10A to 80A, it can be used for cutting materials with a thickness between 0.5 mm and 20 mm, or up to 25 mm in case of separating cuts.

Thanks to the excellent price-performance ratio, the HiFocus 80i makes it possible for many medium-sized enterprises to cut in HiFocus quality.

The HiFocus 80i guarantees high flexibility also for smaller guiding systems and robots for a wide range of conditions of use. The special system configuration HiFocus 80i-Robo is available for the use with robots.

## Versatile Torch Technology

The new generation of PerCut torches has been developed especially for the high demands of the HiFocus technology. They guarantee an increased constriction of the plasma arc by using swirl gases and smaller nozzle diameters and by optimising the gas rotation.

There are a number of different plasma torches available for versatile applications. In addition to the standard torch PerCut 80, the quick-change plasma torch PerCut 90 with bayonet coupling can be used to take advantage of reduced downtimes and easy handling:

- Quick change of technologies due to prepared quick-change torch head
- Quick power adjustment for cutting different material thicknesses
- Comfortable change of consumables due to prepared quick-change torch head

For bevel cutting up to 45° or on three-dimensional parts, e.g. with robots, the plasma torch PerCut 160 (also available with 60° or 90° angled torch head, straight version also available as quick-change plasma torch PerCut 170) with reinforced shaft and 3D consumables is used, thus creating the best conditions for robot-based three-dimensional cutting which is a typical application for example in the automotive industry.

### Technical data

Power source	HiFocus 80i
Cutting current	10-80 A (100% d.c)
Mains voltage	3x400 V, 50 Hz
Fuse, slow	25 A
Connected load	17 kVA
Open circuit voltage	400 V
Ignition	High voltage
Protection class	IP 22
Insulation class	F
Dimension (H x W x D)	1000x510x1020 mm
Weight	161 kg

Plasma torch	PerCut 80/PerCut 90
Standard version	PerCut 80
Quick change system	PerCut 90
Cutting current	max. 100 A
Clamping diameter	
PerCut 80	44 mm
PerCut 90	50 mm
Weight (with 1,5m torch pack)	3,8 kg
Cooling	coolant „Kjellfrost“
Plasma gases	O <sub>2</sub> , Air, N <sub>2</sub>
Swirl gases	O <sub>2</sub> , Air, N <sub>2</sub> , F5

Material	Mild steel			Stainless steel		Aluminium	
	Max. cutting speed <sup>1</sup>	Cutting current (A)	speed (mm/min)	Cutting current (A)	speed (mm/min)	Cutting current (A)	speed (mm/min)
Material thickness (mm)	0,5	20	5000	-	-	-	-
	1	20	3500	30	5000	35	3800
	2	50	2600	55	4000	35	2600
	3	50	2200	55	2600	35	2300
	4	50	4500	60	2200	50	1500
	5	50	3500	60	2000	50	1400
	6	80	3200	60	1800	50	1300
	8	80	2600	-	-	50	1300
	10	80	2300	-	-	-	-
	12	80	1700	-	-	-	-
	15	80	1200	-	-	-	-
	20	80	600	-	-	-	-
	25	80	200	-	-	-	-

<sup>1</sup> The listed cutting speeds depend on material characteristics, gas parameters, the guiding system as well as the consumables. According to the quality parameters of the respective cutting task, the user can change the cutting speed.



# cutting and marking **HiFocus 130 neo**



## Advantages

- ✓ Suited for all common guiding systems as there are CNC-controlled guiding systems, pipe cutting machines or robots
- ✓ High-quality reproducible cutting results due to automatic gas control unit
- ✓ Long lifetime of consumables
- ✓ Higher cutting speeds reduce the costs per cutting metre
- ✓ Nearly dross-free cuts and therefore almost no rework required
- ✓ Low perpendicularity and surface roughness

## neo: new – efficient – original

HiFocus neo systems offer a new higher level of performance. Users benefit from an excellent cutting and marking quality. High speeds improve productivity and lower process costs. Due to optimised technology, HiFocus neo delivers longer consumable life and consistent cut quality over entire parts life. The high-precision unit HiFocus 130 neo can be used for diverse cutting tasks with material thicknesses from 0.5 to 40 mm.

## Cutting faster by 50 %

The patented Contour Cut technology stands for precision when cutting mild steel. Small contours, narrow webs and above all small holes with a hole diameter to material thickness ratio of 1:1 can be cut with Contour Cut in excellent quality. Contour Cut Speed allows the cutting of contours in similar quality with a speed that is up to 50 % higher.

## Application Areas

- Metal construction and engineering
- Steel service centres
- Steel and hall construction
- Plant and tank construction
- Pipeline engineering
- Shipbuilding
- Commercial vehicle industry
- Crane construction
- Offshore constructions
- Wind power plants

## Cost-saving Torch Technique

The Kjellberg plasma torches of the PerCut series are equipped with a unique liquid cooling system which guarantees a long lifetime of the consumables, thus making it possible to achieve savings in the gas consumption. Furthermore, the quick change head reduces the times for changing the consumables. Due to their acuteangled design, difficult-to-access areas can be reached easily and bevel cuts with an angle of up to 50° are possible.

## Robust Consumables

With the long-living consumables made by Kjellberg change times are reduced and the productivity of the cutting process increases. The previously offered range of consumables is expanded by powerful copper cathodes for cutting with oxygen. They are characterised by long lifetime and an excellent price-performance ratio.



## Technical data

Power source	HiFocus 130 neo
Mains voltage <sup>1</sup>	3x400 V, 50 Hz
Fuse, slow	25 A
Connected load	32 kVA
Cutting current	20-130 A
Marking current	16 A
Dimension (H x W x D)	1000x510x1020 mm
Weight	161 kg

<sup>3</sup> Other voltage and frequencies on request.

Plasma torch	PerCut
Standard version	PerCut 201
Quick change system	PerCut 211
Cutting range	0,5 - 40 mm
Clamping diameter	50,8 mm
Plasma gases	O <sub>2</sub> , Ar/H <sub>2</sub> , N <sub>2</sub>
Marking gases	Ar
Swirl gases	O <sub>2</sub> , Air, N <sub>2</sub> , F5 <sup>2</sup>

<sup>2</sup> Forming gas F5 (95 % N / 5 % H)

Material	Mild steel		Stainless steel		Aluminium		
	Max. cutting speed <sup>1</sup>	Cutting current (A)	speed (mm/min)	Cutting current (A)	speed (mm/min)	Cutting current (A)	speed (mm/min)
Anygavastagsåg (mm)	0,5	20	8000	-	-	-	-
	1	20	5500	55	5500	35	3800
	4	60	4100	80	3200	50	1500
	6	90	3700	130	1700	130	3500
	10	130	3400	130	1400	130	1300
	15	130	1900	130	1100	130	1200
	20	130	1300	130	700	130	1000
	25	130	1000	130	500	130	800
	30	130	500	130	400	130	500

<sup>1</sup> The listed cutting speeds depend on material characteristics, gas parameters, the guiding system as well as the consumables. According to the quality parameters of the respective cutting task, the user can change the cutting speed.

plasma cutting from 0.5 to 50 mm

## HiFocus 161i neo



### neo: new – efficient – original

HiFocus neo systems offer a new higher level of performance. Users benefit from an excellent cutting and marking quality. High speeds improve productivity and lower process costs. Due to optimised technology, HiFocus neo delivers longer consumable life and consistent cut quality over entire parts life. The high-precision unit HiFocus 161i neo can be used for diverse cutting tasks with material thicknesses from 0.5 to 50 mm.

### Cutting faster by 50 %

The patented Contour Cut technology stands for precision when cutting mild steel. Small contours, narrow webs and above all small holes with a hole diameter to material thickness ratio of 1:1 can be cut with Contour Cut in excellent quality. Contour Cut Speed allows the cutting of contours in similar quality with a speed that is up to 50 % higher.

### Advantages

- ✓ Suited for all common guiding systems as there are CNC-controlled guiding systems, pipe cutting machines or robots
- ✓ High-quality reproducible cutting results due to automatic gas control unit
- ✓ Long lifetime of consumables
- ✓ Higher cutting speeds reduce the costs per cutting metre
- ✓ Nearly dross-free cuts and therefore almost no rework required
- ✓ Low perpendicularity and surface roughness

### Application Areas

- Metal construction and engineering
- Steel service centres
- Steel and hall construction
- Plant and tank construction
- Pipeline engineering
- Shipbuilding
- Commercial vehicle industry
- Crane construction
- Offshore constructions
- Wind power plants

## Cost-saving Torch Technique

The Kjellberg plasma torches of the PerCut series are equipped with a unique liquid cooling system which guarantees a long lifetime of the consumables, thus making it possible to achieve savings in the gas consumption. Furthermore, the quick change head reduces the times for changing the consumables. Due to their acuteangled design, difficult-to-access areas can be reached easily and bevel cuts with an angle of up to 50° are possible.

## Robust Consumables

With the long-living consumables made by Kjellberg change times are reduced and the productivity of the cutting process increases. The previously offered range of consumables is expanded by powerful copper cathodes for cutting with oxygen. They are characterised by long lifetime and an excellent price-performance ratio.



## Technical data

Power source	HiFocus 161i neo
Mains voltage <sup>1</sup>	3x400 V, 50 Hz
Fuse, slow	50 A
Connected load	28 kVA
Cutting current	10-160 A
Marking current	5-25 A
Dimension (H x W x D)	985x570x1140 mm
Weight	206 kg

Plasma torch	PerCut
Standard version	PerCut 201
Quick change system	PerCut 211
Cutting range	0,5 - 50 mm
Clamping diameter	50,8 mm
Plasma gases	O <sub>2</sub> , Ar/H <sub>2</sub> , N <sub>2</sub>
Marking gases	Ar
Swirl gases	O <sub>2</sub> , Air, N <sub>2</sub> , F5 <sup>2</sup>

<sup>3</sup> Other voltage and frequencies on request.

<sup>2</sup> Forming gas F5 (95 % N / 5 % H)

Material	Mild steel			Stainless steel		Aluminium	
	Max. cutting speed <sup>1</sup>	Cutting current (A)	speed (mm/min)	Cutting current (A)	speed (mm/min)	Cutting current (A)	speed (mm/min)
Anyagvastagság (mm)	0,5	20	6000	-	-	-	-
	1	20	4200	55	5500	35	3800
	4	60	4100	80	3200	50	1500
	6	90	3700	130	1700	130	3500
	10	130	3400	130	1400	130	1300
	15	130	1900	160	1100	160	1500
	20	130	1300	160	800	160	1300
	25	160	1100	160	600	160	1100
	30	160	800	160	500	160	600
	40	160	500	160	300	160	400
	50	160	200	160	100	160	100

<sup>1</sup> The listed cutting speeds depend on material characteristics, gas parameters, the guiding system as well as the consumables. According to the quality parameters of the respective cutting task, the user can change the cutting speed.

# plasma cutting from 0.5 to 120 mm at highest quality

## HiFocus 280i, 360i, 440i neo



### neo: new – efficient – original

HiFocus neo systems offer a new higher level of performance. Users benefit from an excellent cutting and marking quality. High speeds improve productivity and lower process costs. Due to optimised technology, HiFocus neo delivers longer consumable life and consistent cut quality over entire parts life.

The units HiFocus 280i, 360i and 440i neo can be used for diverse cutting tasks with material thicknesses from 0.5 to 120 mm. With the same equipment it is also possible to cut underwater.

### Application Areas

- Metal construction and engineering
- Steel service centres
- Steel and hall construction
- Plant and tank construction
- Pipeline engineering
- Shipbuilding
- Commercial vehicle industry
- Crane construction
- Offshore constructions
- Wind power plants

### Cutting faster by 50 %

The patented Contour Cut technology stands for precision when cutting mild steel. Small contours, narrow webs and above all small holes with a hole diameter to material thickness ratio of 1:1 can be cut with Contour Cut in excellent quality.

Contour Cut Speed allows the cutting of contours in similar quality with a speed that is up to 50 % higher.

## Technical data

Power source	HiFocus 280i neo	HiFocus 360i neo	HiFocus 440i neo
Mains voltage <sup>1</sup>	3x400 V, 50 Hz		
Fuse, slow	100 A	125 A	200 A
Connected load	67 kVA	87 kVA	127 kVA
Cutting current	280 A	360 A	440 A
Marking current	5-50 A		
Dimension (H x W x D)	1030x680x1450 mm		
Weight	505 kg	517 kg	589 kg

<sup>3</sup> Other voltage and frequencies on request.

Plasma torch	PerCut
Standard version	PerCut 441
Quick change system	PerCut 451
Cutting range	0,5 - 120 mm
Clamping diameter	50,8 mm
Plasma gases	O <sub>2</sub> , Ar/H <sub>2</sub> , N <sub>2</sub> , F5 <sup>2</sup>
Marking gases	Ar
Swirl gases	O <sub>2</sub> , Air, N <sub>2</sub>

<sup>2</sup> Forming gas F5 (95 % N / 5 % H)

## Operation data (extract)

### HiFocus 280i, 360i, 440i neo from 0,5 mm

Mat.	Mild steel		Stainless steel		Aluminium	
	Cutting current (A)	Speed (mm/min)	Cutting current (A)	Speed (mm/min)	Cutting current (A)	Speed (mm/min)
0,5	20	8000	-	-	-	-
1	20	5500	55	5500	35	3800
4	60	4100	80	3200	50	1500
6	90	3700	130	1700	130	3500
10	130	3400	130	1400	130	1300
15	130	1900	130	1100	130	1200
20	130	1300	130	700	130	1000
25	130	1000	130	500	130	800
30	130	500	130	400	130	500

### Mild steel, from 20 mm

Type	HiFocus 280i neo	HiFocus 360i neo	HiFocus 440i neo			
Mat. thickness (mm)	Cutting current (A)	Speed (mm/min)	Cutting current (A)	Speed (mm/min)	Cutting current (A)	Speed (mm/min)
20	280	2100	360	2700	400	2800
30	280	1200	360	1550	400	1800
40	280	720	360	1000	400	1150
50	280	400	360	700	400	720
60	280	200	360	450	400	520
70	280	150	360	170	400	320
80	-	-	360	120	440	280
100	-	-	-	-	440	150
120	-	-	-	-	440	100

### Stainless steel, from 20 mm

Típus	HiFocus 280i neo		HiFocus 360i neo		HiFocus 440i neo	
Anyag-vas-tagság (mm)	Vágási áram (A)	Sebes-ség (mm/perc)	Vágási áram (A)	Sebes-ség (mm/perc)	Vágási áram (A)	Sebes-ség (mm/perc)
20	280	1500	360	1700	440	2100
30	280	1000	360	1200	440	1300
40	280	670	360	850	440	1000
50	280	570	360	600	440	750
60	280	430	360	530	440	630
70	280	280	360	420	440	480
80	-	-	360	330	440	440
100	-	-	-	-	440	190
120	-	-	-	-	440	100

### Aluminium, from 20 mm

Típus	HiFocus 280i neo		HiFocus 360i neo		HiFocus 440i neo	
Anyag-vas-tagság (mm)	Vágási áram (A)	Sebes-ség (mm/perc)	Vágási áram (A)	Sebes-ség (mm/perc)	Vágási áram (A)	Sebes-ség (mm/perc)
20	280	3800	360	4000	440	4500
30	280	2200	360	3000	440	2800
40	280	1550	360	1800	440	2400
50	280	1200	360	1500	440	1700
60	280	800	360	1300	440	1300
70	280	450	360	1000	440	1000
80	-	-	360	750	440	850
100	-	-	-	-	440	300
120	-	-	-	-	440	150

<sup>1</sup> The listed cutting speeds depend on material characteristics, gas parameters, the guiding system as well as the consumables. According to the quality parameters of the respective cutting task, the user can change the cutting speed.

cutting efficiently from 0.5 to 160 mm

# HiFocus 600i neo



## neo: new – efficient – original

With a maximum cutting current of 600 A the plasma cutting system HiFocus 600i neo sets new standards: Materials with a thickness of up to 160 mm can be cut precisely; also marking and bevel cutting is possible.

For cutting mild steel fast and precisely the patented Contour Cut technology is applied. Consisting of two power sources and an external cooling unit the plasma cutting system can be used in combination with CNC-controlled guiding systems, robots or pipe cutting machines and for underwater plasma cutting.

## Technical data

	HiFocus 360i neo	Power Modul HiFocus 600i neo
Conn. load max.	87 kVA	93 kVA
Cutting current	10-360 A	10-600 A
Marking current	5-50 A	-
Cutting range	0,5-160 mm	
Gas control	automatic: FlowControl	

## Robust Consumables

With the long-living consumables made by Kjellberg change times are reduced and the productivity of the cutting process increases. The previously offered range of consumables is expanded by powerful copper cathodes for cutting with oxygen. They are characterised by long lifetime and an excellent price-performance ratio.

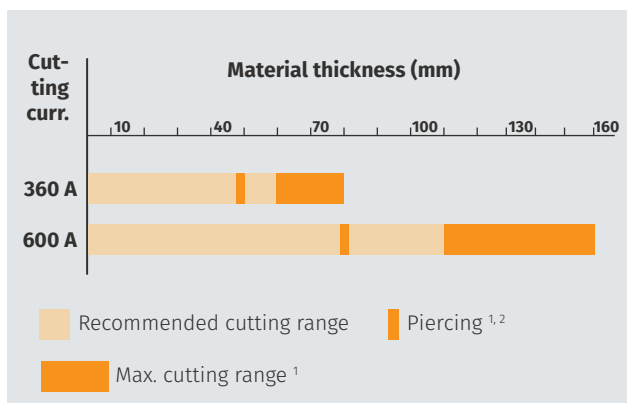

<sup>1</sup> These data are depending on the materials to be cut and their compositions. <sup>3</sup> Observe piercing capability!



# robust and reliable equipment for the upper cutting range

## FineFocus 450, 600, 800, 1600



The robust plasma cutting units of the FineFocus series offer highest reliability and good cut quality even under extreme conditions. At the same time they achieve high efficiency due to the low gas consumption. The user is presented with a product of highest quality in an attractive price-performance-ratio.

Electrically conductive materials with a thickness of 3 mm to 160 mm can be cut reliably.

The plasma cutting units can be adapted to CNC-controlled guiding systems and robots quickly and easily. With FineFocus it is possible to use also compressed air as plasma gas.

### Advantages at a glance

- ✓ Clean cut surfaces and therefore low rework costs
- ✓ Use of the swirl gas technology for dry and underwater plasma cutting
- ✓ Angular deviations ranging between 2 and 4 according to the standard DIN EN ISO 9013 and high cutting speeds on mild steel due to the FineFocusPLUS technology
- ✓ High efficiency and low running costs due to the integrated or external closed-circuit cooling and therefore lower gas consumption
- ✓ Long lifetime of consumables
- ✓ Microprocessor-controlled system for smooth and controlled process cycle



## FineFocus 800

The FineFocus 800 is the most powerful power source of the FineFocus series and offers very good results when cutting medium-sized and thick materials. The plasma cutting unit can be used for straight, contour and bevel cutting up to 50° dry and under water.

Two versions are available:

### ■ FineFocus „Single“

Equipped with one plasma torch connection. With the machine torch materials up to 80 mm can be cut.

### ■ FineFocus „Twin“

Allows the connection of two plasma torches which can be operated alternately; one of them can be a manual torch.

## Fields of Application

- Steel and hall construction
- Tank and plant construction
- Metal and mechanical engineering
- Shipbuilding
- Job-shop
- Disassembling
- Offshore constructions
- Wind power stations

## Technical data

Power source	FineFocus 450	FineFocus 600	FineFocus 800	FineFocus 800 UWP <sup>1</sup>	FineFocus 1600
Mains voltage <sup>2</sup>	3~, 400 V, 50 Hz				
Fuse, slow	50 A	100 A	125 A	160 A	2x160 A
Connected load	34 kVA	60 kVA	83 kVA	100 kVA	2x100 kVA
Cutting current (100% d.c)	40 - 100 A (75% d.c.)	40 - 200 A	80 - 300 A	80 - 300 A	160 - 600 A
Dimension (L x W x H)	1025 x 711 x 970 mm	980 x 644 x 1320 mm	1370 x 870 x 1505 mm	1370 x 870 x 1505 mm	2 x 1370 x 870 x 1505 mm
Mass	251 kg	370 kg	566 kg	564 kg	2x 564 kg
Plasma gases	O <sub>2</sub> , N <sub>2</sub>	O <sub>2</sub> , Ar, H <sub>2</sub> , N <sub>2</sub>	O <sub>2</sub> , Ar, H <sub>2</sub> , N <sub>2</sub>	O <sub>2</sub> , Ar, H <sub>2</sub> , F5*	O <sub>2</sub> , Ar, H <sub>2</sub> , F5*
Swirl gases	Air, N <sub>2</sub>	Air, N <sub>2</sub>	Air, N <sub>2</sub>	Air, N <sub>2</sub>	Air, N <sub>2</sub>

<sup>1</sup> Underwater plasma <sup>2</sup> Other voltage and frequencies on request.

\* Forming gas F5 (95 % N / 5 % H)

## FineFocus 1600

The maximum cutting performance of 600 A is achieved by connecting two FineFocus 800 in parallel thus forming a FineFocus 1600 with external water cooling. The FineFocus 1600 is preferably used for the automated cutting of stainless steel and aluminium up to 160 mm in combination with CNC-controlled guiding systems. It is possible to connect up to three different types of plasma torches.

## HotWire Technology

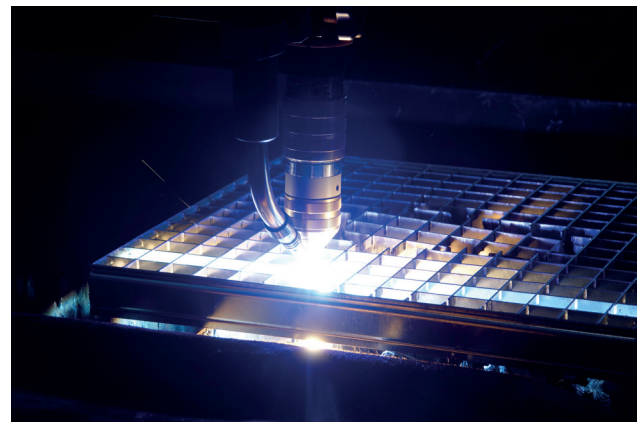

The FineFocus 800 can be modified quickly and easily for applying the HotWire technology. Electrically conductive, non-conductive, combined and interrupted materials e.g. gratings, armoured concrete or wired glass can be cut with this technology.

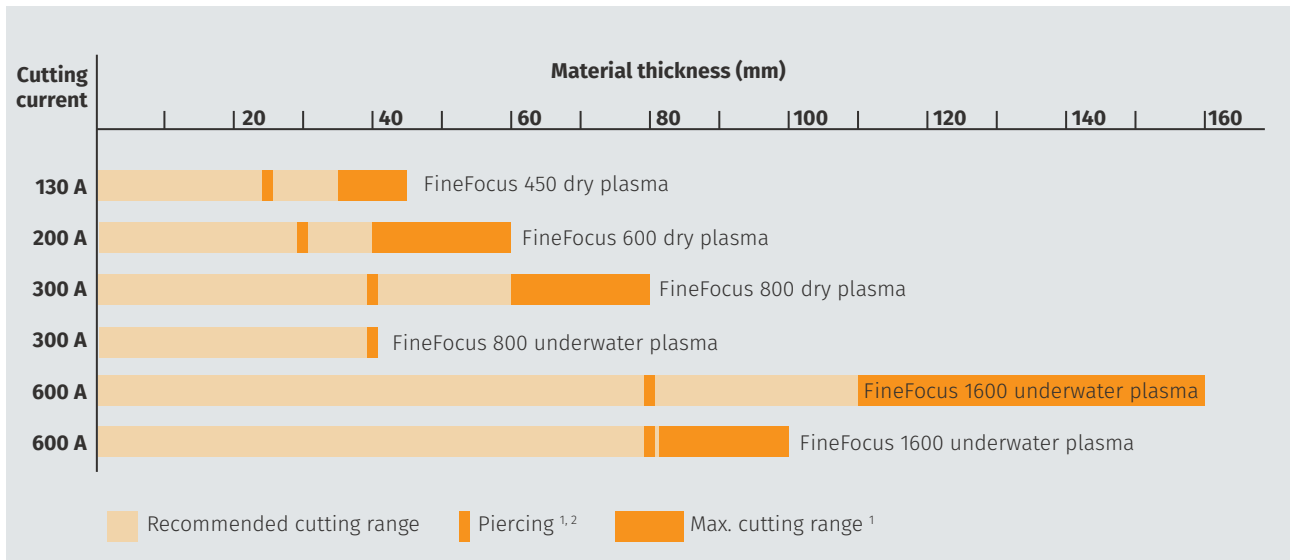

<sup>1</sup> These data are depending on the materials to be cut and their compositions. <sup>3</sup> Observe piercing capability!

### FineFocus 450

Mat. thickness (mm)	Un- and low-alloyed steels		Alloyed steel		Aluminium	
	Cutting current (A)	Speed (mm/min)	Cutting current (A)	Speed (mm/min)	Cutting current (A)	Speed (mm/min)
6	130	2800	130	1900	130	8000
10	130	1900	130	1900	130	5000
15	130	850	130	750	130	3000
20	130	750	130	500	130	1800
25	130	450	130	450	130	1200
30	130	350	130	430	130	850
40	130	200	120	200	120	500

### FineFocus 800

Mat. thickness (mm)	Un- and low-alloyed steels		Alloyed steel		Aluminium	
	Cutting current (A)	Speed (mm/min)	Cutting current (A)	Speed (mm/min)	Cutting current (A)	Speed (mm/min)
6	200	7500	200	3800	200	9000
10	200	5000	200	3000	200	8000
15	200	4500	200	240	200	7000
20	250	3800	250	2200	250	4500
25	250	2300	250	1600	250	3700
30	300	1500	250	1000	150	2200
40	300	1100	250	700	250	1400
50	300	600	300	450	250	1200
60	300	350	300	250	250	800
70	300	200	300	150	250	250
80	300	100	300	100	250	150

### FineFocus 600

Mat. thickness (mm)	Un- and low-alloyed steels		Alloyed steel		Aluminium	
	Cutting current (A)	Speed (mm/min)	Cutting current (A)	Speed (mm/min)	Cutting current (A)	Speed (mm/min)
6	60	3600	200	3800	60	2500
8	120	3100	200	3200	100	4600
10	120	2500	200	2400	100	3800
15	200	2600	200	1900	200	4200
20	200	2300	200	800	200	3800
30	200	1000	200	600	200	1200
40	200	650	200	350	200	950
50	200	300	200	250	200	750
60	200	250	200	150	200	500

### FineFocus 1600

Alloyed steel					
PB-S151 (csak Ar/H <sub>2</sub> )			PB-S100 WU		
Mat. thickness (mm)	Cutting current (A)	Speed (mm/min)	Mat. thickness (mm)	Cutting current (A)	Speed (mm/min)
60	600	500	60	500	400
80	600	250	80	600	170
100	600	200	100	600	180
120	600	150	120	600	195
150	600	100	150	600	100

<sup>1</sup> The listed cutting speeds depend on material characteristics, gas parameters, the guiding system as well as the consumables. According to the quality parameters of the respective cutting task, the user can change the cutting speed.

pure energy

## SmartFocus 130, 200, 300



### Simply good cutting

With just a few settings the compact plasma cutting units of the Smart Focus series achieve excellent results in the cutting range from 1 to 80 mm – even under most challenging conditions. The Smart Focus units can also be used for marking, bevel and underwater cutting.

### Contour Cut technology

All Smart Focus units are equipped with the Contour Cut technology for cutting mild steel: Small contours, narrow webs and holes with a diameter to material thickness ratio of 1:1 can be cut in excellent quality. Contour Cut Speed allows the cutting of contours with a speed that is up to 50 % faster.

### Torches & gas control – intelligent redevelopment

Newly developed gas supply units are available for the Smart Focus series, either manual or fully automated. With these the user achieves best cutting results with highest, reproducible quality. The new torches PerCut 2000 and PerCut 4000 have been improved as well. They provide precise cuts and highest cutting speeds. Their unique cooling system guarantees longest consumable life and reduces the gas consumption und cutting costs per metre.

## Advantages

- ✔ Highest cutting quality
- ✔ High cutting speed
- ✔ Low perpendicularity
- ✔ User-friendly & easy to service
- ✔ Less cutting meter costs

## Application areas

- Application areas
- Metal construction & engineering
- Job shop production
- Steel & hall construction
- Plant & tank construction
- Commercial vehicle & crane construction
- Pipeline & ventilation construction
- Shipbuilding & automotive engineering
- afm

## Technical data

Power source	SmartFocus 130	SmartFocus 200	SmartFocus 300
Mains voltage	3 x 400 V, 50 Hz	3 x 400 V, 50 Hz	3 x 400 V, 50 Hz
Fuse, slow	50 A	100 A	125 A
Connected load max.	28 kVA	51 kVA	79 kVA
Cutting current (100% d.c)	35 - 130 A	35 - 200 A	35 - 300 A
Marking current (100% d.c)	12 - 50 A	12 - 50 A	12 - 50 A
Dimension (L x W x H)	1030 x 570 x 1260 mm	1030 x 680 x 1450 mm	1030 x 680 x 1450 mm
Weight	266 kg	388 kg	488 kg

SmartFocus	Mild steel		Stainless steel		Aluminium	
	Cutting current (A)	Cutting speed (mm/min)	Cutting current (A)	Cutting speed (mm/min)	Cutting current (A)	Cutting speed (mm/min)
Material thickness (mm)						
1	135	2600	60	8000	35	6000
2	35	1600	60	7000	35	6000
4	60	4100	60	5000	60	3300
5	60	3100	60	4000	60	3100
6	90	3700	130	1600	130	3500
8	130	3700	130	1500	130	1400
10	130	3400	130	1400	130	1300
12	200	3000	130	1200	130	1200
15	200	2800	200	1500	200	3800
20	200/300	1800/2600	200/300	850/1500	200/300	3300/3800
30	200/300	1000/1500	200/300	600/1000	200/300	3300/2200
40	300	1100	300	670	300	1500
50	300	600	300	570	300	1200
60	300	350	300	430	300	800
70	300	150	300	280	300	450
80	300	100	300	170	300	200

# The Next Level

## New: SmartFocus 400

We extend our plasma series and its application range for precise and efficient plasma cutting.

### Advantages

- ✓ Extension of the Smart Focus series
- ✓ Excellent cutting results with just a few settings
- ✓ Operation also under challenging conditions
- ✓ Highest cutting speeds
- ✓ User friendly & easy to service

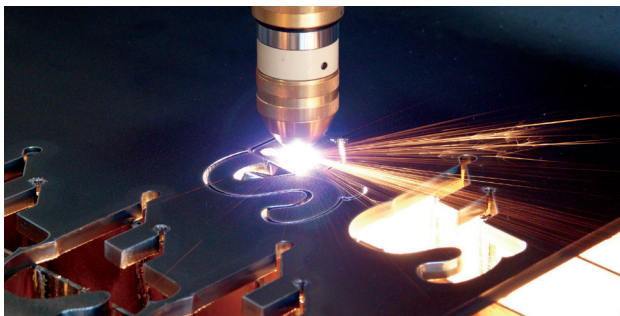

### Application areas

- 2D plasma cutting
- Bevel cutting up to 50°
- Underwater plasma cutting
- Marking
- Cutting of all electrically conductive materials up to 100 mm material thickness

### Technical data

Power source	SmartFocus 400
Mains voltage	3 x 400 V, 50 Hz
Fuse, slow	180 A
Connected load	116 kVA
Cutting current (100%)	35 - 400 A
Marking current (100%)	10 - 50 A
Dimensions (L x W x H)	1030 x 680 x 1450 mm
Weight	563 kg

Cutting range max.	100 mm	
Cutting range recommended	Stainless steel	Mild steel
	70 mm	60 mm
Piercing	50 mm	
Plasma torch	PerCut 4000	
Plasma gases	O <sub>2</sub> , Ar/H <sub>2</sub> , N <sub>2</sub> , air	
Swirl gases	O <sub>2</sub> , N <sub>2</sub> , F <sup>5</sup> , air	
Marking gases	Ar, N <sub>2</sub>	

<sup>2</sup> F5 forming gas: 95% N<sub>2</sub>, 5% H<sub>2</sub>

# cutting and plasma gouging with hand or machine torch

## PA-S45W, PA-S70W



The plasma cutting systems of the PA-S series are suitable for manual and mechanised cutting of material thicknesses in the range from 3 to 70 mm. The use of a range of different plasma gases and gas mixtures allows the clean cutting and gouging of electrically conductive materials. As portable systems, they can be used in workshops, training centres and on construction sites. The cost-efficient units of the PA-S series offer good cutting results for simple applications. The liquid-cooled plasma torch allows the use of air, oxygen, argon and hydrogen as plasma gas. Furthermore, these robust plasma cutting units can be operated with hand and machine torches.

### Advantages

- Attractive price-performance ratio
- Optional use of hand or machine torch
- Suitable for 2D and 3D guiding systems
- Robust and simple design
- Portable systems for mobile use
- Reliable even under challenging production conditions
- Simple operation and maintenance with a service and diagnostic system
- Cutting current with three settings
- Fluid cooling of plasma torch for long consumable life
- Quick switch from cutting to plasma gouging
- Angled torch heads and special shaft designs for optimised cutting of 3D parts

### Application Areas

- Metal construction and engineering
- Plant and tank construction
- Pipeline engineering
- Scrap cutting
- Dismantling

## Technical data

Power source	PA-S45W	PA-S70W
Mains voltage	3x400 V, 50 Hz	3x400 V, 50 Hz
Fuse, slow	63 A	125 A
Connected load max.	38 kVA	76 kVA
Cutting current	45 A (100% d.c.) 85 A (100% d.c.) 130 A (60% d.c.)	80 A (100% d.c.) 160 A (100% d.c.) 240 A (100% d.c.)
Dimension (L x W x H)	1025 x 711 x 970 mm	1380 x 870 x 1080 mm
Weight	240 kg	460 kg

<sup>3</sup> Other voltage and frequencies on request. <sup>2</sup> Forming gas F5 (95 % N / 5 % H)

Plasma torch	PB-S44W	PB-S45W	PB-S70W
Cutting current (100% d.c.)	130 A	130 A	250 A
Cutting range	40 mm-ig	45 mm-ig	70 mm-ig
Plasma gas	Air, AR/H <sub>2</sub> mix.	Air, AR, H <sub>2</sub>	Air, AR/H <sub>2</sub> mix.
Swirl gas	Air, N <sub>2</sub>	-	-
Torch cooling	„Kjellforst“		

PA-S45 W	Mild steel		Stainless steel		Aluminium	
	Cutting current (A)	Cutting speed (mm/min)	Cutting current (A)	Cutting speed (mm/min)	Cutting current (A)	Cutting speed (mm/min)
3	45	2000	-	-	-	-
5	85	2500	85	2500	85	3400
10	130	2000	130	2150	130	3000
15	130	1300	130	1700	130	2100
20	130	800	130	1000	130	1300
25	130	500	130	700	130	900
40	130	200	130	200	130	300
45	130	200	130	200	130	150

PA-S70 W	Mild steel		Stainless steel		Aluminium	
	Cutting current (A)	Cutting speed (mm/min)	Cutting current (A)	Cutting speed (mm/min)	Cutting current (A)	Cutting speed (mm/min)
4	160	3000	160	2630	-	-
6	160	3150	160	2200	160	3500
8	160	2500	160	1750	160	3000
10	240	2600	160	1500	160	2000
15	240	1300	160	1000	160	1700
20	240	1100	240	1050	240	1750
30	240	800	240	530	240	1250
40	240	500	240	500	240	1000
50	240	230	240	350	240	600
60	240	200	240	200	240	350
70	240	125	-	-	240	250

<sup>1</sup> The listed cutting speeds depend on material characteristics, gas parameters, the guiding system as well as the consumables. According to the quality parameters of the respective cutting task, the user can change the cutting speed.

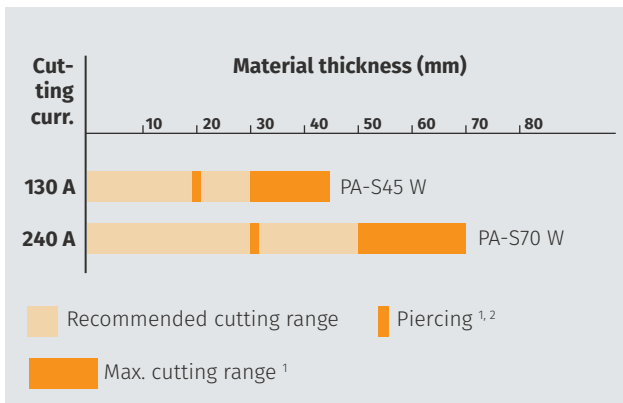

<sup>1</sup> These data are depending on the materials to be cut and their compositions. <sup>3</sup> Observe piercing capability!

# powerful plasma cutting inverters at low investment costs

## CutFire 65i, 100i



For cutting electrically conductive materials with thicknesses from 1 to 20 mm Kjellberg offers the air-cooled plasma cutting inverters of the CutFire series. These plasma cutting units are particularly suited for simple and economic cutting tasks.

The CutFire 100i achieves a cutting current of 100 A at 100 % duty cycle and is thus suited for continuous operation. The CutFire 65i is characterised by its compact design and low weight. The powerful and cost-efficient inverters can be used flexibly especially in heating, ventilation and pipeline engineering. Therefore the CutFire 65i and CutFire 100i can easily be adapted to CNC guided and mechanical guiding systems.

### Advantages

- Easy to use plasma cutting equipment
- Low consumable costs
- Use of air as plasma gas
- Easy pressure adjustment and monitoring
- Stepless setting of cutting current for optimal performance
- Straight and contour cutting

### Application Areas

- Heating, ventilation and air condition engineering
- Pipeline engineering
- Steel and mechanical engineering
- Craft businesses, production and industrial plants



## Technical data

Power source	CutFire 65i	CutFire 100i
Plasma torch	KjelCut 70 Flash 100 G/L	Flash 100 G/L
Mains voltage <sup>1</sup>	3x400 V, 50 Hz	
Fuse, slow	25 A	
Connected load max.	9,8 kVA	166 kVA
Cutting current	65 A (100% d.c.) 50 A (100% d.c.)	100 A (100% d.c.)
Dimension (L x W x H)	470 x 180 x 270 mm	710 x 280 x 590 mm
Weight	17 kg	50 kg

<sup>1</sup> Other voltage and frequencies on request.

Plasma torch	KjelCut 70	KjelCut 100
Cutting range	1 to 12 mm	1 to 20 mm
Plasma gas	Air	
Torch cooling	Air	
Air consumption	140 l/min	140 l/min, 265 l/min
Pressure	5 bar	5 bar   6,5 bar
Torch shaft diameter	-	36 mm

CutFire 100i	Mild steel		Stainless steel		Aluminium	
	Material thickness (mm)	Cutting current (A)	Cutting speed (mm/min)	Cutting current (A)	Cutting speed (mm/min)	Cutting current (A)
1	35	10200	35	6500	35	5500
3	70	7000	70	5000	70	5000
6	100	4300	70	2700	70	3000
8	100	3200	100	3000	100	3000
10	100	2000	100	1900	100	2200
12	100	1800	100	1300	100	1700
15	100	1200	100	700	100	1400
20	100	400	100	320	100	800

The listed cutting speeds depend on material characteristics, gas parameters, the guiding system as well as the consumables. According to the quality parameters of the respective cutting task, the user can change the cutting speed.

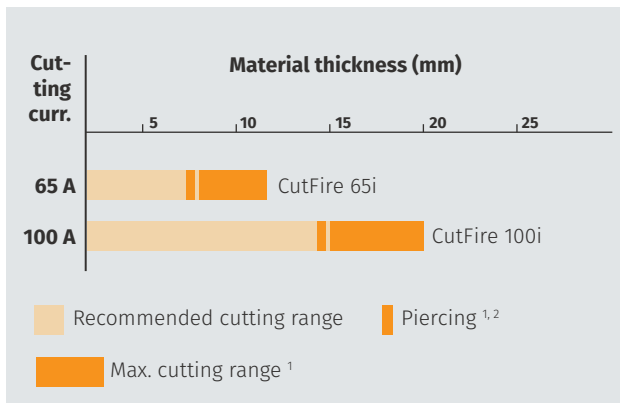

<sup>1</sup> These data are depending on the materials to be cut and their compositions. <sup>3</sup> Observe piercing capability!

# cutting up to 50 mm with CUTi and CUTLINE

## CUTi, CUTLINE



The small power packages of the CUTi series are easy to handle and thus especially suitable for mobile use. From among the models of the series, the user may choose the unit which meets his individual requirements best.

With the plasma gas air mild steel, stainless steel, aluminium, brass, copper and other electrically conductive materials can be cut.

All CUTi inverters operate with gas-cooled plasma torches and external compressed air supply. The CUTi 35C is additionally equipped with an integrated compressor. Due to the sinusoidal power consumption with PFC (power factor correction), the inverter CUTi 35 draws its maximum power from the single-phase 230 V mains.

### Advantages of CUTi

- ✓ Light, portable, easy to handle
- ✓ Productive due to high cutting speed
- ✓ Energy saving due to modern inverter technique
- ✓ High cut quality
- ✓ Versatile use due to a large variety of accessories
- ✓ Safe working due to safety shut-down, also at workplaces with increased electrical endangerment
- ✓ Maintenance unit for trouble-free cutting

### Advantages of CUTLINE

- ✓ Low operating costs with liquid-cooled plasma torches
- ✓ Low material loss and reduced toxic emissions due to narrow kerfs
- ✓ Cut surfaces usable on both sides
- ✓ Plasma gouging without after-treatment
- ✓ Cutting start from the outside with burning pilot arc

## Technical data

	CUTi 35C	CUTi 35	CUTi 70	CUTi 90	CUTi 120
Mains voltage <sup>1</sup>	1 x 230 V			3 x 400 V	
Fuse, slow	16 A	16 A	16 A	25 A	25 A
Connected load max.	3,3 (4,8 <sup>1</sup> ) kVA	3,7 kVA	11,1 kVA	15 kVA	16,7 kVA
Protection class	IP 23	IP 21	IP 21	IP 21	IP 23
Cutting current	12 - 25 (35 <sup>1</sup> ) A	5 - 35 A	27 - 70 A	26 - 90 A	25 - 120 A
Duty cycle	25% - 35 A 30% - 25 A 100% - 20 A	40% - 35 A 60% - 28 A 100% - 22 A	35% - 70 A 60% 128 A 100% - 50 A	40% - 90 A 60% - 74 A 100% - 50 A	35% - 120 A 60% 95 A 100% - 80 A
Cutting range	6 (10 <sup>1</sup> ) mm	12 mm	30 mm	35 mm	50 mm
Ignition	Drawn arc	Drawn arc	Hight voltage	Hight voltage	Hight voltage
Plasma gas	Air				
Pressure	0,4 Mpa <sup>1</sup>	0,4 Mpa	0,5 Mpa	0,5 Mpa	0,5 Mpa
Air consumption	115 l / min	70 l / min	140 l / min	195 l / min	195 l / min
Dimnesion (H x Sz x Ma)	500 x 150 x 245 mm	480 x 150 x 225 mm	470 x 180 x 250 mm	470 x 180 x 250 mm	610 x 230 x 410 mm
Weight	12,5 kg	10 kg	16,4 kg	17 kg	28,5 kg

<sup>1</sup> With extended compressed air supply

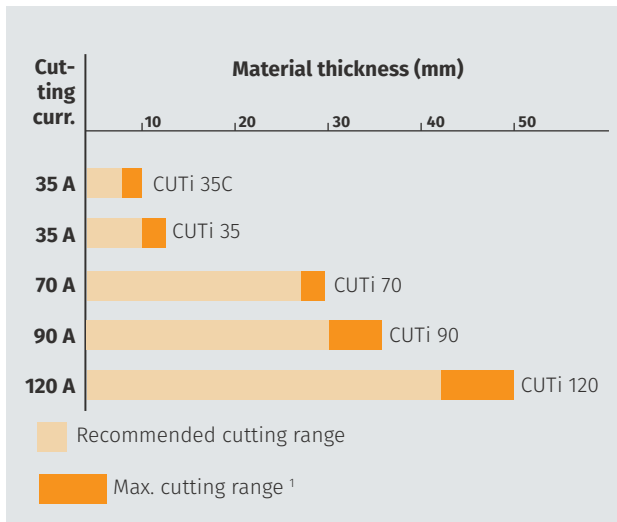

<sup>1</sup> These data are depending on the materials to be cut and their compositions. <sup>3</sup> Observe piercing capability!

	CUTLINE 20W	CUTLINE 40W
Mains voltage <sup>1</sup>	3 X 230 V / 400 V	3 X 400 V
Fuse, slow	32/25 A	32 A
Connected load max.	16 kVA	24 kVA
Protection class	IP 22	IP 22
Cutting current	25 - 50 A	50 - 100 A
Duty cycle	60 %	
Cutting range	20 mm	40 mm
Ignition	High voltage	
Cooling	Kjellforst	
Plasma gas	Air	
Pressure	0,5 Mpa	0,5 Mpa
Air consumption	25 l / min	
Dimnesion (H x Sz x Ma)	670 x 490 x 880 mm	820 x 490 x 880 mm
Weight	84 kg	132 kg

<sup>1</sup> With extended compressed air supply

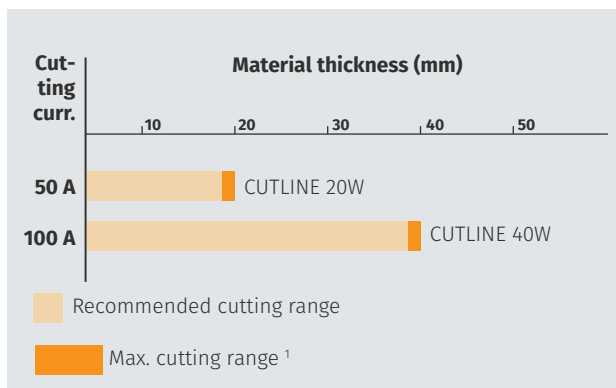

<sup>1</sup> These data are depending on the materials to be cut and their compositions.

# for marking, notching and punching FineMarker



The marking of materials is relevant for a number of applications. These include for example markings for subsequent manufacturing processes like punch marks for borings, scribing marks for subsequent cutting processes or marking of part numbers. It is an advantage that the marking depth is manually adjustable. In addition to temper colours which are not visible anymore after finishing, you can also produce deep markings which are visible even after colouring.

With the FineMarker we offer you an external unit which can easily be integrated into your present cutting system, no matter whether it is an older plasma or an oxy-fuel cutting system.

## Positive Points for the FineMarker

- ✓ Point for point punch setting for drill-holes
- ✓ Temporary or fixed marking of materials
- ✓ Mark setting and lettering for further operations
- ✓ Measure marking on workpieces

## Technical data

FineMarker	
Mains voltage <sup>1</sup>	3 X 400 V
Fuse, slow	16 A
Connected load max.	5,2 kVA
Marking current	4-25 A
Cutting range	50 - 100 A
Duty cycle	100 %
Marking gas	Ar / levegő
Marking speed	1,5 - 12 m/perc
Plasma gas consumption	7 l/perc
Dimension (H x Sz x Ma)	710 x 400 x 440 mm
Weight	30 kg

## Plasma Marking System

- Marking of mild steels, alloyed steels and primed plates; suitable also on wet and greasy surfaces
- Marking speed 1.5mup to 12 m/min
- Marking depth and width adjustable by plasma arc
- Duty cycle 100 %, torch water cooled
- Easy notching and punching operation by parameter control
- Digital display of current and voltage Interface for CNC-controls;
- optional: Marking current from CNC and output of marking voltage

Versatile · Efficient · Safe

## Plasma Cutting with Robots

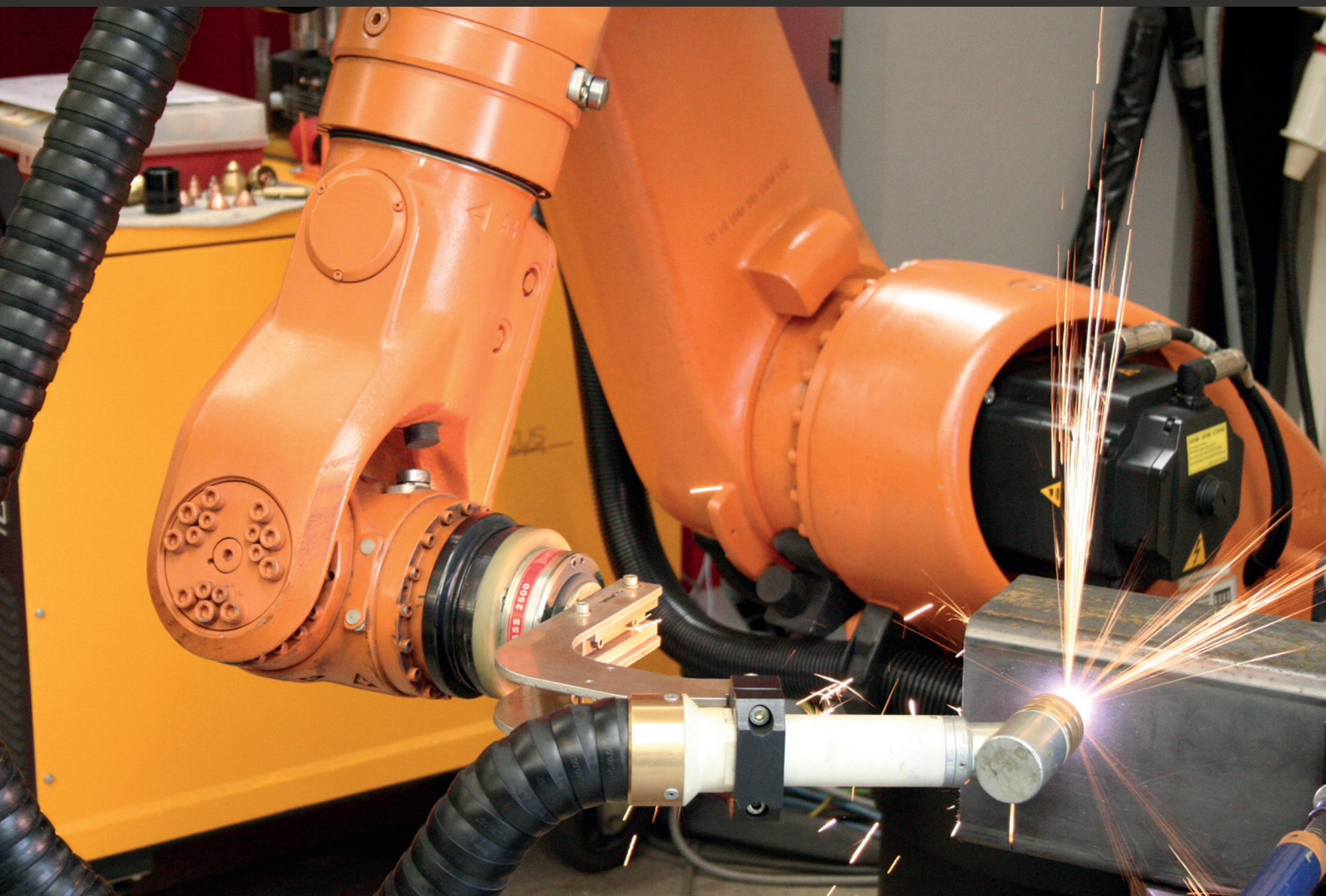

Today, robot-assisted cutting technique is mainly used for the processing of three-dimensional workpieces. The most important users are the automotive industry and its suppliers as well as enterprises in container and pipe production, steel construction and shipbuilding. In these sectors, the plasma cutting technique has already many times proven its advantages with regard to flexibility and cost benefits compared to other technologies.

### Plasma Torches for Special Applications

For plasma cutting with robots, Kjellberg Finsterwalde has developed a wide variety of torches. Depending on the task, several models are on offer:

- As straight version or with 60° or 90° angled cutting heads – they make it possible to cut even highly structured work-pieces optimally
  - With quick-change head
- With Kjellberg plasma torches, bevel cuts up to 50° are possible. In connection with special torches, bevel cuts up to 60° are possible.

Industrial robots are excellently suited for economic large-scale production, for effective low-volume production and even for piece production.

Kjellberg plasma cutting systems can be adapted to all robots and robot controls in the market.

**Robot-assisted plasma cutting offers all features that are required for the use in industry and craft:**

- Cost-efficient cutting
- Simple programming and operation
- High cutting speeds
- High cut quality, nearly no rework required
- High flexibility

**It is possible to cut all electrically conductive materials and diverse types of work-pieces:**

- Structural components for vehicles
- Pipes and containers
- Hollow profiles, open and closed profiles as well as bulb flat profiles
- Dished bottoms

**Plasma cutting with robots offers a number of possible applications:**

- Cutting on pre-selected paths or of work-pieces with greater tolerances on paths with automatic torch height control
- Vertical cutting (straight cuts and holes)
- Complex three-dimensional contours
- Precise and variable bevel cutting
- With some systems also marking
- Underwater plasma cutting
- Plasma cutting on hot work-pieces

At present, Contour Cut is the latest way of highquality plasma cutting.

It is the further development of the HiFocus technology for cutting fine inner and outer contours in mild steel and convinces with:

- High cut quality and contour accuracy
- Low angular deviations and smooth cut Surfaces
- Excellent repeatability and dimension accuracy
- High productivity at low costs

**Technical data**

Power source	HiFocus 80i	HiFocus 130	HiFocus 161i
Cutting current at 100% d.c.	10-80 A	20-130 A	10-160 A
Marking current	-	16 A	5-25 A
Recommended cutting range <sup>1</sup>	0,5 - 15 mm	0,5 - 25 mm	0,5 - 25 mm
Max. cutting range	20 (25°) mm	20 (25°) mm	20 (25°) mm
Max. piercing	15 mm	25 mm	25 (30°)
Bevel cutting up to	45°	45°	45°
Plasma torch	PerCut 160-2 LS	PerCut 160-2 LS	PerCut 160-2 LS

Power source	HiFocus 280i	HiFocus 360i	HiFocus 440i	FineFocus 800
Cutting current at 100% d.c.	10-280 A	10-360 A	10-440 A	80-300 A
Marking current	5-50 A	5-50 A	5-50 A	-
Recommended cutting range <sup>1</sup>	0,5 - 50 mm	0,5 - 60 mm	0,5 - 60 (80°) mm	5-60 mm
Max. cutting range	70 mm	80 mm	120 mm	80 mm
Max. piercing	40 mm	50 mm	50	40 mm
Bevel cutting up to	50°	50°	50°	45°
Plasma torch	PerCut 450M Robo	PerCut 450M Robo	PerCut 450M Robo	PB-S80 W-2 Robo

<sup>1</sup> Listed material thicknesses depend on the kind of material.

\* With 2D consumables

# for conductive, non-conductive and interrupted materials

## HotWire Plasma



The indirect plasma cutting process is the basis for cutting interrupted structures. In contrast to direct plasma cutting, the plasma arc burns between the cathode and the nozzle of the plasma torch. The HotWire technology uses neither the work piece nor the nozzle as anode, but a wire that is constantly fed into the cutting process. Non-conductive materials, i.e. glass-fibre reinforced plastics, concrete, reinforced concrete, ceramics but also glass, wired glass and textiles can be cut by using this technology.

A HotWire plasma system includes the power source (FineFocus 800 or HiFocus 360i) and its components and the following additional equipment:

- Wire feeding unit and GMAW torch
- Motive wire feeding unit, variable
- Holder and adjusting device for torch and wire feeding unit

### System Features

- All other possible applications of the plasma system without HotWire can be used to full extent
- Easy and safe mounting of additional components
- Automatic activation of all additional components upon start of the cutting process

### Areas of Application

- Straight and contour cuts
- Gratings, tube bundles and hollow profiles
- Mineral materials, i.e. clinkers, glass or concrete

### Advantages

- ✓ The cut qualities are similar to direct plasma cutting
- ✓ No break-off of the main arc at the „end of work piece“
- ✓ No pre-heating of the material required

# adjusting and dosing of the plasma and swirl gases

## Plasma Gas Unit - FlowControl



For achieving best cutting result the gas mixture and the flow rate of the plasma and swirl gases are essential. The automatic gasbox FlowControl contains the necessary cutting data for the cutting process. It controls the volume flow and the timing of the single process gases and ensure thus otimised and reproducible gas mixtures by:

- ✓ Tailored gas mixture in dependence of the cutting material
- ✓ Reliable adjustment of the gas parameters due to microprocessor control and monitoring
- ✓ Balance of pressure fluctuations
- ✓ Safe dosage, for even the smallest gas flows of different mixture
- ✓ Avoiding operating errors

The cutting data and marking data for different materials and material thicknesses can be accessed and used from the factory-adjusted cutting database. Specific or modified cutting data can be saved in a special customer database.

The FlowControl can also be installed in existing guiding systems without database capabilities. The FlowControl consists of the plasma gas controller PGC and the plasma valve unit PGV. It can be ontrolled by a serial interface.



# ATChanger unit increases user productivity

## Automatic Torch Changer



**The ATChanger allows for the first time the automatic swapping of plasma torch heads.** Being the world's first quick-change unit, it is a key element towards the automation of plasma cutting.

It is based on the quick-change system used for Kjellberg Finsterwalde plasma torches which has been implemented and further developed for the ATChanger.

This autonomously working unit was initially fitted for the dimensions of the PerCut 370 ("Automatic") plasma torch. Thus, it is **suitable for use with the HiFocus 280i, HiFocus 360i and HiFocus 440i** plasma cutting machines.

### The advantages for the user are quite straight-forward

- ✔ due to reduced downtime periods, a longer availability of the cutting system can be achieved which increases user productivity
- ✔ the system can be fitted with up to eight plasma torch heads with consumables for constant cutting tasks
- ✔ a variety of cutting tasks can be performed by fitting the machine with up to eight different torch heads – using different cutting technologies for different materials
- ✔ quick change between highest cutting output and finest marking is possible
- ✔ no release of collision protection necessary because of effortless change of torch head.

Thanks to an integrated control system, the ATChanger is able to execute an unassisted torch change. In order to keep changeover times as short as possible an internal analysis is used to choose the shortest way to the requested torch head.

The installation of the torch head needed for the respective cutting task is carried out through a service opening at the side which provides easy access for the operator.

The adjustment of the torch heads in the magazine is realised by the well-proven 5-groove-system which guarantees an exact positioning of torch head and shaft, allowing the swapping process to run quickly and safely.

It is a main feature of the ATChanger that it can be used both with 2D and 3D guiding systems. Time saving is a major advantage for the operator of this unit. The plasma cutting system's capacity can be better utilised, manual changeover times are no longer required and the cutting system can be operated nearly unmanned.

### Technical data

	ATChanger
Mains voltage	230 V AC
Compressed air	6 bar
Magazine positions	8 pozíció
Dimension (L x W x H)	600 x 300 x 820 mm
Plazma torch <sup>1</sup>	PerCut 370A
Interfaces (Tool management via guiding system guide system)	digital input/output, RS232/RS485 (serial), Ethernet
Weight	75 kg

<sup>1</sup> Version for automatic swapping

# high energy density Laser cutting systems

The laser beam is a widespread versatile technology for material processing, which provides an effective solution to production in many cases. It is used in the industry mostly for cutting, engraving and welding. By using a laser source of the correct type and power, the majority of materials can be processed well. The highly focusable laser beam enables the precise production of complex and finely drawn work pieces in large series.

In order to select the laser cutting system, it is essential to determine the type and thickness of the material to be cut, as well as the expected cut rate and the surface quality. Typically, the type of the beam source, the wavelength and energy of the emitted beam, and the pulse technology used will determine the application range. Please ask our experts' advice so that we can build a system that is optimized for you.

## Application examples

- marking technology, information systems
- decorative engraving, advertising design
- manufacturing of front and back covers as well as PCBs of instruments
- processing table plates
- cutting of pipes and gauges
- precision welding technology

## Typical materials that can be cut

- ✓ ductile iron, carbon and stainless steels
- ✓ polymers, wood, composites, textiles, ceramics, PVC
- ✓ plastics, PMMA
- ✓ copper, bronze, zinc, aluminum, titanium

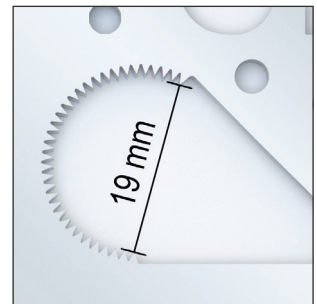
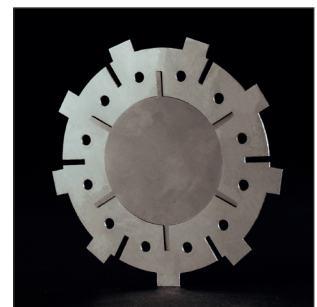
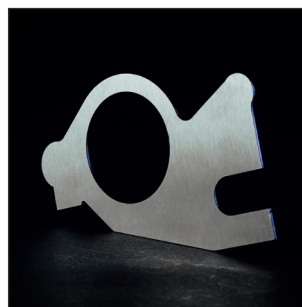

complete laser cutting equipment

# PreciTrack® PTL2030

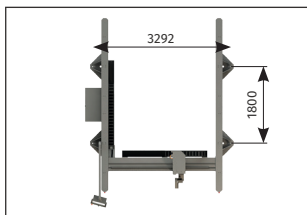
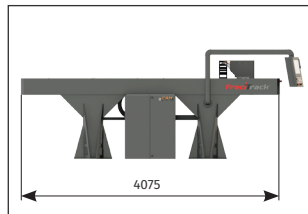
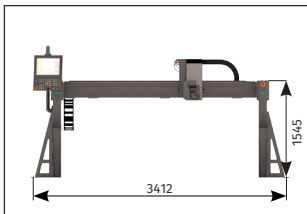

PreciTrack PTL2030 Technical data	
X Y Z Axis	3418x3850x1800 mm
Work area	2000x3000 mm
Weight	~ 1500 kg
Load capacity	~ 1500 kg
Power	~ 13 kW
Drive	Digital AC servo
Rapid traverse speed X	90 m/perc
Rapid traverse speed Y	90 m/perc
Rapid traverse speed Z	30 m/perc
Maximal step precision	0,01 mm
Operational step precision	0,02 mm
Retrack precision	0,02 mm
Cutting technology	XFocus Fiber lézer 1 kW
No. of heads	1 db lézer
Max. cutting current	160 A
Max. noise level dB(A)	80 dB
Control	NCT201

We designed the complete unit above according to the industrial averages so it is an applicable solution for most manufacturers but if you have other production demands you can naturally order a different configuration, as well. Due to the PreciTrack coordinate track the size, technology and accessory units can be changed in a flexible way.

laser cutting from 0.5 to 15 mm

## Fiber Laser XFocus 500, 1000, 2000



For marking and cutting of small and large contours on mild steel, stainless steel and aluminium ProCAM Ltd offers the compact fiber laser systems XFocus 500, XFocus 1000 and XFocus 2000. In addition to cutting thin sheets the systems can be combined with a plasma cutting unit or used separately and can be adapted easily to our PreciTrack/NCT guiding system.

### Cutting & marking

The fibre laser systems XFocus 500, 1000 and 2000 are ready-made complete solutions for cutting and marking of mild steel to 15 mm, stainless steel to 8 mm and aluminium to 6 mm. They can be used on common guiding systems, either separately or in combination with a plasma cutting unit or other tools such as punch.

### Cutting database – setting of all parameters

The fibre laser systems of the XFocus series are equipped with an integrated technology database for selecting the optimum cutting parameters. The user can choose from up to nine different cutting speeds depending on material and thickness. The complete cutting process with hole and edge cutting regime can be loaded from the database. All required parameters such as gas pressure, height control and the setting of the motoric focal position of the laser head are available on demand.

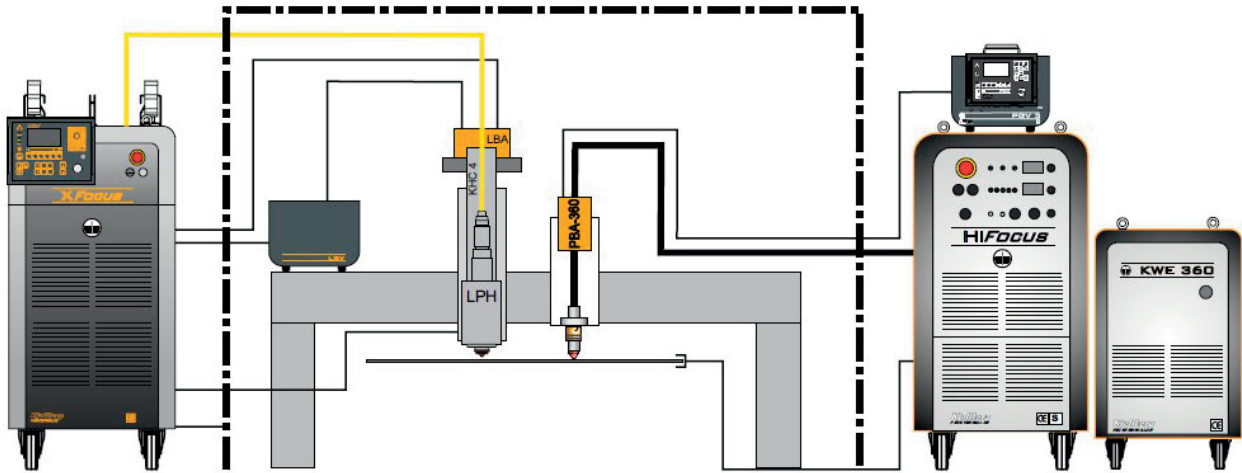

**Connecting system: Usable on guiding system such as our PreciTrack/NCT system in combination with plasma cutting unit.**

### Technical data

Fiber laser	XFocus 500	XFocus 1000	XFocus 2000
Power	500 W	1000 W	2000 w
Wave length	1070 nm		
Mains voltage	400-480 V; 3 Ph.; 50/60 Hz		
Connected load max.	6 kVA	7 kVA	
Fuse, slow	GL/GG 32 A		
Cutting range			
Mild steel	0,5-5 mm	0,5-10 mm	
Stainless steel	0,3-3 mm	0,3-5 mm	
Aluminum	1-2 mm	1-3 mm	
Gas supply	O2 ; N2 ; Air		
Dimension (L x W x H)	1035 x 695 x 1590 mm		1250 x 810 x 1500 mm
Weight	2700 kg	300 kg	300 kg

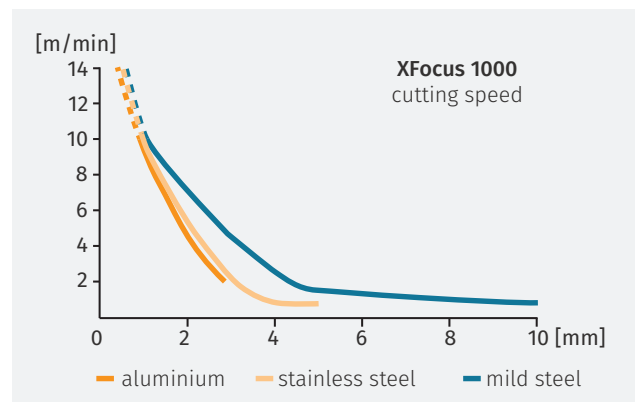
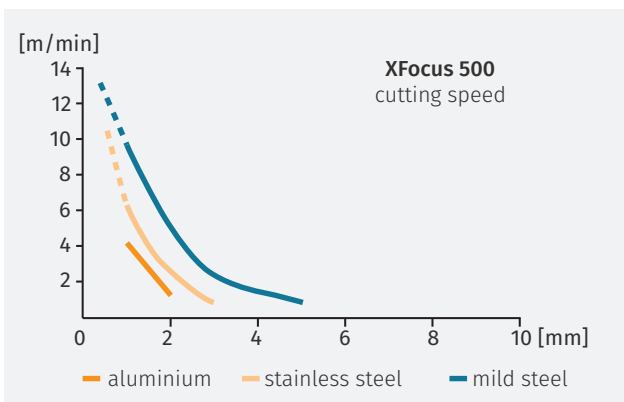

# SPI Fiber Laser Sources

SPI fiber laser has many beneficial properties, which makes a lot of applications easier. Using the proper mechanical and optical accessories, fiber laser can be used to process flat plates, 3D objects, pipes, etc., therefore it can be considered a very flexible tool. Thanks to low maintenance costs and high efficiency, the manufacturing cost of products can be kept low economically and also in the long run.

The fiber laser of the **redPOWER R4** series has been specifically developed by SPI, to take into account reliability, performance and user safety.

## OEM version

- Water-cooled
- Maintenance-free
- Easy to be integrated
- with 10 m fiber optic cable
- Excellent laser beam quality:
  - M2<1.1 – 1.0kW – 1.5kW
  - M2=6.5 – 1.5kW – 3kW
  - M2=10 – 1.5kW – 6kW
- Continuous and modulated mode
- Patented laser connector
  - Laser reflection measurement

1.0kW – 1.5kW



3kW, 4.5kW, 6kW



## Boxed version

- Water-cooled
- Maintenance-free
- Complete solution
- with 10 m fiber optic cable
- Excellent laser beam quality:
  - M2<1.1 – 1.0kW – 1.5kW
  - M2=6.5 – 1.5kW – 3kW
  - M2=10 – 1.5kW – 6kW
- Continuous and modulated mode
- Patented laser connector
  - Laser reflection measurement

1.0kW – 1.5kW



3kW, 4.5kW, 6kW



# Cutting optics

Dynamic laser cutting machines require lightweight, intelligent cutting heads. Even installed in the smallest possible space, the ProCutter offers a fully-integrated sensor system that monitors the cutting process and provides the user with relevant information. The head ensures that each component can be reproducibly manufactured at a high standard of quality.

## ProCutter For all tasks

- Lightweight and slim design
- Motorized focal point adjustment
  - For automatic adjustment and puncture
- Continuous protective glass monitoring
- Fully closed, dust-protected beam path, with protective glass
- LED display - operating status feedback
- With integrated proximity sensors for surface tracking
- Monitoring of cutting gas pressure at the nozzle end



### ProCutter - Technical data

max. laser power	6 kW (with wave lengths of 1030 - 1090nm)
electronics	Lasermatic®
focal length collimation FC	100 mm
focal lengths FF	125 mm, 150 mm, 175 mm, 200 mm
NA <sub>max</sub>	0.13 at FC100
vertical adjustment range	FC100/FF125: +6 mm/-9 mm; FC100/FF150: +9 mm/-13 mm; FC100/FF175: +12 mm/-18 mm; FC100/FF200: +15 mm/-20 mm
dimension (WxD)	92 x 115 mm
weight	4.2 kg (straight version, FF 125 mm)

## ProCutter Zoom For dynamic laser cutting machines

- Zoom lens for diameter adjustment with auto focus
- Motorized focal point adjustment
  - For automatic adjustment and puncture
- Continuous protective glass monitoring
- Fully closed, dust-protected beam path, with protective glass
- LED display - operating status feedback
- With integrated proximity sensors for surface tracking
- Monitoring of cutting gas pressure at the nozzle end



### ProCutter Zoom - Technical data

max. laser power	6 kW (with wave lengths of 1030 - 1090nm)
electronics	Lasermatic®
focal length collimation FC	150 mm
magnification ratio	1.25 / 1.5 / 1.75 / 2 / 2.25 / 2.5
dimension (WxD)	92 x 115 mm

# Technology for the most wide circle of applications

## Integratable (OEM) CO<sub>2</sub> lasers

**The most fundamental tool of laser processing is the laser itself. A whole series of applications is built on laser devices custom-made for certain tasks. UNIVERSAL OEM manufactures its laser sources for such custom-made machines between 10W and 150W performance limits.**

### CO<sub>2</sub> laser technology

The CO<sub>2</sub> laser technology offers touch-free processing for materials such as plastics, wood, leather, ceramics executing cutting, marking and engraving tasks. The wavelength characteristic of this laser type can be absorbed in these materials the best way which is a prerequisite of laser processing. The absorbed energy is transformed into heat which melts the material along the cutting line. If the laser energy is high enough, it will completely vaporize the material in its whole cross-section resulting in a clean and smooth cutting surface. At a lower laser performance the heat energy absorbed in the material generates a chemical or thermic reaction which creates a constant, distinctive marking. This marking burns into the material so it is a suitable method for applying identifying marks on different products.

**CO<sub>2</sub> laser are typically available in two wavelengths for slightly different areas of applications.**

Universal manufactures laser sources with one resonator until 75W, while offering two resonator laser sources in the 100, 120

and 150W performance category. The two resonator, cross-polarized laser source provides more options in material processing.

#### The applications of the 10.600nm (10.6 μm) laser

- Engraving, cutting and marking of plastics, wood, textiles, leather and laminated sheets
- Aluminium, ceramics, stone, glass marking

#### The applications of the 9.300nm (9.3 μm) wavelength laser

- Suitable for high contrast markings on PET bottles, photo-polymer materials and other light-sensitive plastics

#### General characteristics

- Water or air cooling version
- Built-in indicator laser
- TTL temperature feedback LED
- Fault signal LED
- High performance stability
- Low noise emission
- RoHS compatibility

### Laser specifications

Performance	10 – 150W	Optical delay	38 ± 10 μs
Wave length	10.6 μm and 9.3 μm	Optical modulation	100%, 5kHz-ig
Performance stability	±5% after 5 min of CW operation	Weight	9.5 – 40.8 kg
M2	1.3 ± 0.2	Environment	
Beam diameter	4 ± 1 mm	Environmental temperature	10 – 40 oC
Beam opening angle	5 ± 1 mm	Relative humidity	<95% (non-condensing)
Polarization	Linear	DC input voltage	48 VDC
Modulation signal type	TTL compatible	Electrical input	20 – 50 A



## OEM lasers

The OEM laser range includes both CO<sub>2</sub> and fibre technologies, they are designed to be easily integrated into a range of work flow solution and applications. This laser can be used in CW (continuous) or modulated (average performance) operation.

- The separated RF electrodes create a high quality laser beam with minimum beam expansion.
- Due to the covered resonator the performance is compact.
- The Universal lasers do not need recharging, providing a long life-span.

CO<sub>2</sub> gas laser is an important technology in processing non-metallic materials. This 10.600 nm wavelength laser is suitable for the marking, engraving, cutting and welding of plastics, ceramics, wood, glass, etc. Its use is widespread in the advertising industry, marketing and visual technological companies and in stamp production. Universal laser systems are designed and built for versatility.

**Our systems are equipped with features that can help you in enhancing your business opportunities and conquering new markets.**

## Most widespread applications

- Architectural model making
- Food industry
- Plastic and textile cutting
- Gifts and souvenirs
- General production technology
- Packaging
- Paper industry
- Prototype production
- Marking technology
- Rubber stamp manufacturing
- Wood industry
- Advertising industry

## Variations in structure

**Air cooling:** variation without external cooling unit that ensures the cooling and temperature stability required for the laser technology by cooling fans and ribs. In case of integration it is possible to use an already installed air cooling so the fan is not necessary.

**Water cooling:** if the environmental temperature fluctuation exceeds the required limits it is advisable to use a water cooling unit. The inner piping of the laser source provides the effective cooling with a standard 3/8" connection on the input and output. The cooling liquid is standard distilled water.



## Products

Performance	Basic air cooling	Integrated air cooling	Basic water cooling	Integrated water cooling	4-s class air cooling	4-s class water cooling	9.3 μm
10W	•	•	•	•	•	•	
25W	•	•	•	•	•	•	•
30W	•	•	•	•	•	•	•
40W	•	•	•	•	•	•	
50W	•	•	•	•	•	•	•
60W		•		•	•	•	
75W		•		•	•	•	
100W		•		•	•	•	
120W		•		•	•	•	
150W		•		•	•	•	

Technical description	UL-25/30	UL-35/40	UL-45/50	UL-60	ULC-70/80	ULC-90/100
<b>Nominal performance</b>	25 vagy 30 watt	35 vagy 40 watt	45, 50 vagy 60watt	45, 50 vagy 60watt	70 vagy 80 watt	90 vagy 100 watt
<b>Wavelength</b>	10.6μ	10.6μ	10.6μ	10.6μ	10.6μ	10.6μ
<b>Performance stability</b>	+/-5% after 15 minutes CW operation	+/-5% after 15 minutes CW operation	+/-5% after 15 minutes CW operation	+/-5% after 15 minutes CW operation	+/-5% after 15 minutes CW operation	+/-5% after 15 minutes CW operation
<b>Beam quality (M2)</b>	1.2+/-0.2	1.2+/-0.2	1.4+/-0.2	1.4+/-0.2	1.2+/-0.2	1.2+/-0.2
<b>Beam diameter</b>	4+/-1mm	4+/-1mm	4+/-1mm	4+/-1mm	4+/-1mm	4+/-1mm
<b>Beam angle (full angle)</b>	5+/-1mR	5+/-1mR	5+/-1mR	5+/-1mR	5+/-1mR	5+/-1mR
<b>Beam ellipticity</b>	<1.4:1	<1.4:1	<1.4:1	<1.4:1	NA	NA
<b>Polarization</b>	Linear	Linear	Linear	Linear	Random	Random
<b>Target stability</b>	200μR	200μR	200μR	200μR	200μR	200μR
<b>Ramp-up and shut down time</b>	120+/-40μS	120+/-40μS	120+/-40μS	120+/-40μS	120+/-40μS	120+/-40μS
<b>Optical modulation</b>	100% up to 5KHz	100% up to 5KHz	100% up to 5KHz	100% up to 5KHz	100% up to 5KHz	100% up to 5KHz
<b>Modulation signal</b>	TTL Compatible	TTL Compatible	TTL Compatible	TTL Compatible	TTL Compatible	TTL Compatible
<b>Excitation</b>	On/Off, Adjustable with Dipswitch	On/Off, Adjustable with Dipswitch	On/Off, Adjustable with Dipswitch	On/Off, Adjustable with Dipswitch	On/Off, Adjustable with Dipswitch	On/Off, Adjustable with Dipswitch
<b>Cooling</b>	Air (built-in)	Air (built-in)	Air (built-in)	Air (built-in)	Air (built-in)	Air (built-in)
<b>Weight</b>	8kg	10kg	(built-in)	12kg		
<b>Environment</b>						
<b>Environment temperature (operational)</b>	10-35°C					
<b>Relative humidity</b>	< 90% (Non-condensing)					
<b>Energy demand</b>						
<b>DC input voltage</b>	48.0 VDC	48.0 VDC	48.0 VDC	48.0 VDC	48.0 VDC	48.0 VDC
<b>Average current (continuous operation, including cooling fan)</b>	10 A	14 A	18 A	18 A	28 A	36 A
<b>Excitation current intensity</b>	70 A, 150μS	70 A, 150μS	70 A, 150μS	70 A, 150μS	140 A, 150μS	140 A, 150μS

safe process flow

## Height control units

The voltage-dependent height control units made by Kjellberg guarantee the precise distance between the torch and the work-piece surface. A constant torch height during cutting and the lifting during piercing guarantee the highest cut quality and a safe process flow.

### Voltage-dependent height control unit **KHC4-PCS**

Height control unit for all high-precision plasma cutting applications. The KHC4-PCS system provides all the essential functions that are needed for consumable-saving piercing and a constant height control as a condition for good cut quality.

- For all HiFocus and FineFocus applications
- Installation or retrofit to any guiding system possible for modernisation of existing cutting workstations
- Integrated 3-dimensional collision protection
- Working load up to 12 kg
- Lifting 220 mm

### Features

- Easy adaption to all common guiding systems,
- Tactile finding of initial position on work-piece surface (smooth touching), pressure for initial position finding is adjustable and thus also possible for thin sheets.
- Height adjustment in 0.1 millimeter steps („cutting height mode“) or in 0.5 Volt steps („arc voltage mode“).
- High work-piece utilisation due to precise height measurement also close to kerfs and edges. (On kerfs, edges and corners the arc lengthens and the arc voltage increases. The automatic kerf detection switches the height control off when the arc voltage exceeds the adjustable limit. It is again activated when the voltage value is back to the original level. The guiding system transfers a signal as soon as a corner is cut (corner function). In this case, too, the arc is prevented from being too long and having a negative influence on the cut quality.)



- Additionally adjustable height increase during piercing protects the consumables from spatter (slag),
- Adjustment of short torch lifting between contours possible
- Torch clamp with 3D collision protection with +/-17 ° deflection, optionally with intelligent collision detection,
- Adjustable weight compensation
- High lifting speed of max. 80 mm/s,
- Controls for dynamic at linear drive (control response time and control delay time)
- Standard connection with CUTBUS® for CNC control via guiding system or alternatively with Operator Terminal
- Isolated arc voltage input from 0 to -300 VDC

## Display and Control Unit

- Manual adjustment via Operator Terminal
- KCU 4 is the interface between height control unit, plasma cutting unit and CNC-control of the guiding system

## Technical data

	<b>KHC4-PCS (Linear drive with Kjellberg Connection Unit KCU 4 and operation terminal)</b>
Working load	up to 12 kg
Lifting	220 mm (standard), 350 mm (opcionális)
Max. lifting speed	80 mm/sec
Torch clamp for torch diameter	30-58 mm
Collision protection for torch	- Deflection ca. ± 17 ° in all direction - Collision protection (automatic torch lifting) - Automatic resetting - Deflection force adjustable
Operation voltage	230 V AC/ 110V AC (auto select input)
Isolated input for arc voltage	0-300 V DC or 0-10 V
Piercing time	0,2 – 5 sec
Weight	9 kg (Linear drive) 0.4 kg (operation terminal)
Dimension (H x W x D)	Linear Drive (without guide bar): 400 x 125 x 128 mm Operation terminal: 120 x 160 x 35 mm

# Height Control Unit B 1000

The height control unit B 1000 is easy to use for all plasma applications and provides all essential functions that are needed for a constant distance between the torch and the material thus allowing good cuts and optimum utilization of the workpiece. Cutting height is preferably entered in mm and guarantees exact torch-workpiece-distance; independently from wearing of cathode.

- For all power sources of the types CutFire, PA-S, FineFocus and HiFocus
- Installation or retrofit on any guiding system possible for modernization of existing cutting workstations
- Lifting of up to 200 mm and working load of up to 10 kg
- Integrated collision protection



## Features





- Simple adaption to all common guiding systems,
- Tactile finding of initial position on work-piece surface
- The cutting height can be adjusted in millimeters / inch ("cutting height mode") or in Volt steps (ARC voltage mode)
- Intuitive, easy operation due to visual presentation of the sequence
- LED status indication
- Display of cutting voltage during operation
- Kerf detection and corner function
- Additional height control protects moving parts protects against hot slag
- Torch clamp with collision protection
- Isolated input of cutting voltage recognizes automatically polarity and range of cutting voltage 0-10 V or 0-300 V

## Technical data

Height control unit B 1000	
Lifting	200 mm
Max. lifting speed	80 mm/s (4.8 m/min)
Working load	10 kg
Torch clamp for torch diameter	30-58 mm
Collision protection for torch	Integrated collision protection
Operating voltage	230V AC
Inputs for control signals	24 V DC
Outputs for control signals	20 V DC
Isolated input for arc voltage	0-300 V DC / ( 0 to 10V DC )
Weight	6.8 kg (+1.9 kg Contor Unit)
Dimensions Linear Drive	360 x 180 x 125 mm (H x W x D)
Dimensions Operator Interface	235 x 111 x 122 mm (H x W x D)

# Notes

A series of horizontal dotted lines for writing notes.

Cutable materials	 Flame cutting	 Laser cutting	 Milling	 Plasma cutting	 Waterjet cutting
Mild steel	x	x	x	x	x
Carbon steel	x	x		x	x
Stainless Steel		x		x	x
Aluminium		x	x	x	x
Titanium		x	x	x	x
Chrome and cobalt alloy		x		x	x
Copper		x	x	x	x
Bronz		x		x	x
Zink		x		x	x
Plexi		x	x		x
Polycarbonate			x		x
Foamed materials		x	x		x
PVC			x		x
PET		x	x		x
Other plastics		x	x		x
Rubber					x
Wood		x	x		x
Marble, Terazzo			x		x
Granit					x
Glass					x

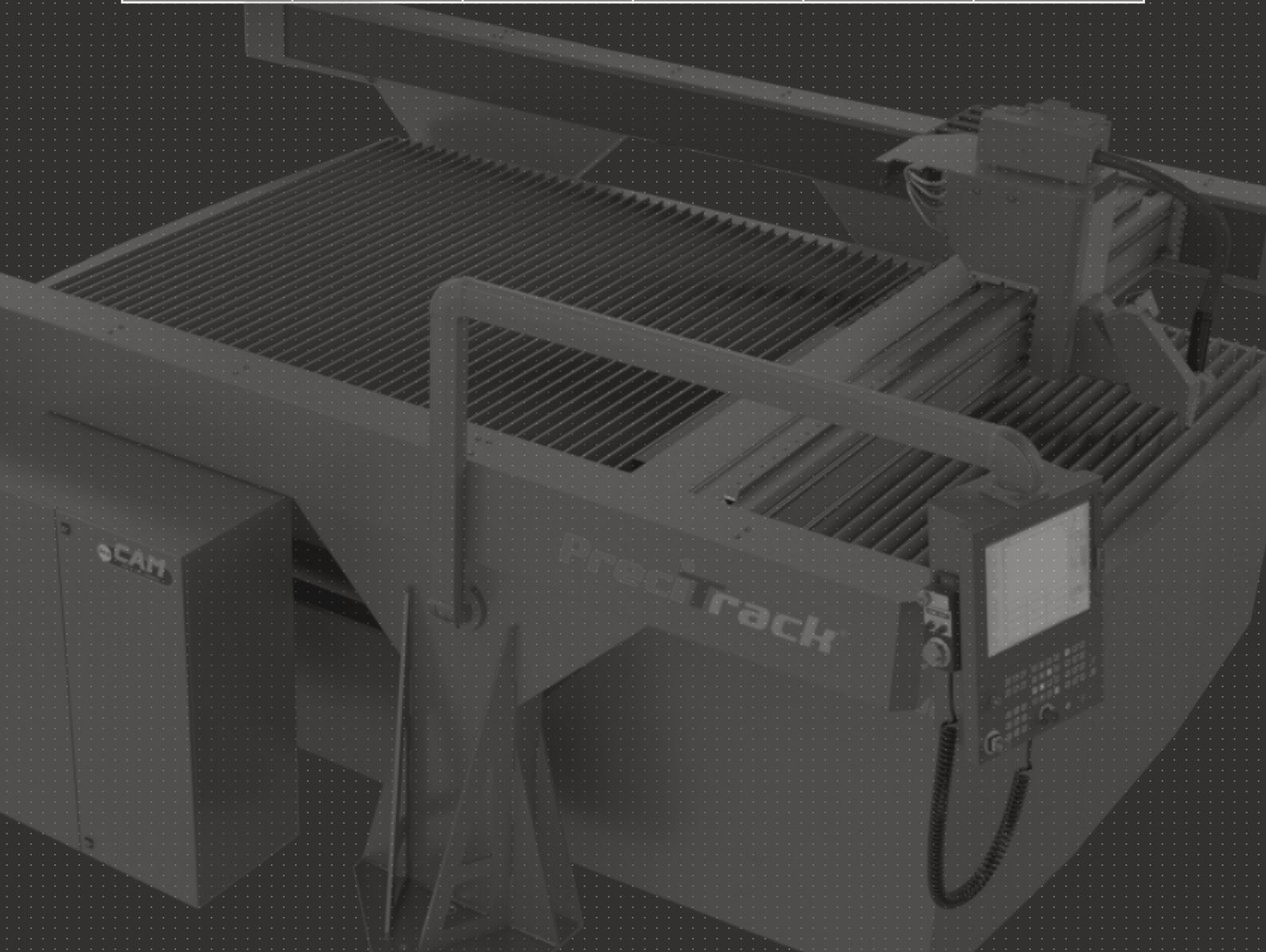



**ProCAM Engineering and Development Ltd.**

Factory Hungary-2142 Nagytarcsa, Ganz Ábrahám utca 4.  
Office Hungary-2142 Nagytarcsa, Ady Endre u. 36/A.  
Phone/Fax +36 28 737 046  
E-mail [info@procamkft.hu](mailto:info@procamkft.hu)  
Internet [www.precitrack.com](http://www.precitrack.com)